

microframe®

SERIES 9000

INSTALLATION & SPECIFICATION GUIDE

**ITEM NO: D9010-7010
REVISION DATE: 08/10**



Microframe Corporation
604 S. 12th Street
Broken Arrow, OK 74012

Tel: (918) 258-4839
Toll Free: 1-800-635-3811
Website: www.microframecorp.com
E-mail: support@microframecorp.com

D9010-7010



Limited Warranty Agreement

Your Microframe System is warranted against failure due to defects in workmanship or material for a period of one (1) year from the date of purchase. Microframe Corporation will repair or replace any defective unit. Obvious abuse or mishandling of the unit is NOT covered by this warranty.

Merchandise Return

If your Unit does not work satisfactorily, please give us a call. We may be able to clear up the problem by phone. If it becomes necessary to return your Unit to the factory, please observe the following.

1. Place Unit in a sturdy box with sufficient packing material.
2. If requested, include the power supply. It is not necessary to return the cable and connectors unless they are the problem.
3. Return the system insured and prepaid since we are not responsible for shipping damages and losses on returned Units.

Warranty Service

For warranty service, please contact Microframe at 1-800-635-3811. A technician will gladly assist you.

Assistance

For any product assistance or maintenance help, contact Microframe by either calling 1-800-635-3811 or emailing us at support@microframecorp.com.

Safety

Do not install substitute parts or perform any modification to the product without first contacting Microframe.

Warning

All power transformers, line cords, and electrical equipment should be kept out of the reach of children and away from water. (If you are installing cable in an air plenum area, such as a drop ceiling used for air return, you must use plenum-rated cable. The cable supplied from Microframe is rated CL2 and is approved for installation everywhere indoors except plenum areas.)

Life Support Policy

Microframe's products are not authorized for use as components in life support devices or systems without the express written approval of the president of Microframe Corporation. As used herein:

1. Life support devices or systems are defined as systems which support or sustain life, and whose failure to perform when properly used in accordance with instructions for use provided in the labeling, can be reasonably expected to result in a significant injury to the user or any one depending on the system.

2. A critical component is any component of a life support device or system whose failure to perform can be reasonably expected to cause the failure of the life support device or system, or to affect its safety or effectiveness.

Disclaimer

We are constantly striving to improve our products. Due to this, specifications are subject to change without notice.

TABLE OF CONTENTS

	DETAILED VISUAL-PAGER CONNECTION	4
	VISUAL-PAGER CONNECTION DIAGRAM	5
	MAXIMUM CABLE LENGTH CHART	6
1	INSTALLATION PROCEDURES	7
2	KEYPAD OPERATION.....	8
3	KEYPAD OPTIONS.....	10
4	DISPLAY OPERATION.....	11
	EXPLANATION OF ERROR CODES	12
	TROUBLESHOOTING CHART	12

DETAILED VISUAL-PAGER CONNECTION

STEP 1:

Remove slide-on cover.

STEP 2:

Remove 1.5" of jacket from cable and separate wires.

Strip 1/4" of insulation from each wire and pre-form wires as shown.

STEP 3:

Insert Black Wire in one of the terminals marked GND.

Insert Red Wire in one of the terminals marked SIG.

Tighten terminal screws using a 1/8" Slotted Screwdriver.

STEP 4 (If required):

If a second set of wires are required at the Keypad, repeat Step 3 being careful not to reverse the SIG and GND connections.

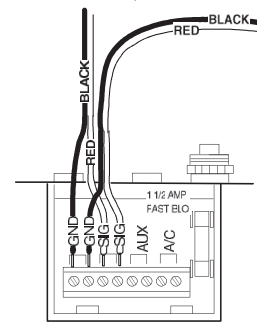
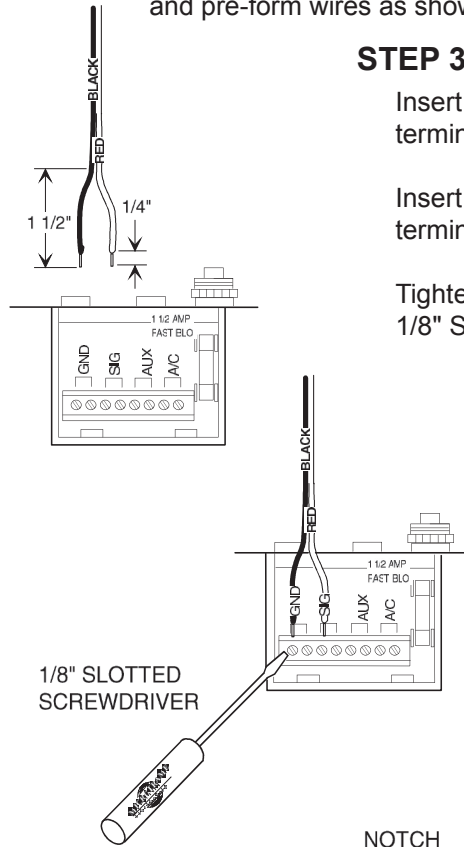
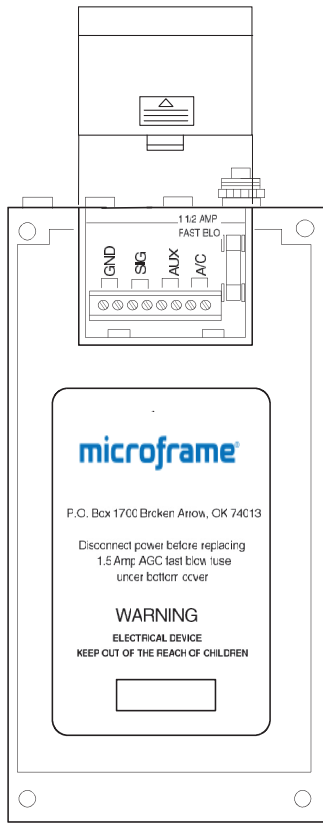

STEP 5:

Install slide-on cover being careful to first form wires so the Ty-wrap is inside the case as shown. The slide-on cover has a notch for the wires to fit through.

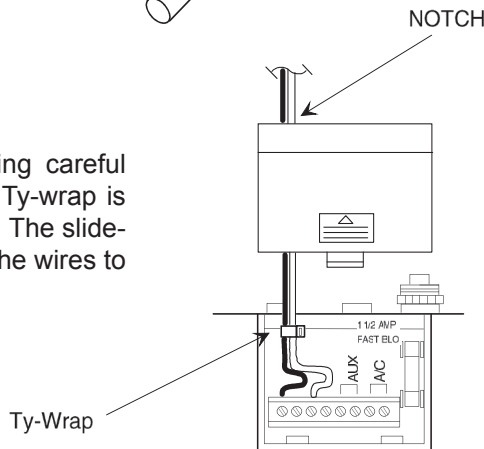

904\axl9703.DRW

MAXIMUM CABLE LENGTH CHART

The following chart shows the maximum number of remote displays that can be installed per cable length indicated. The cable length can be increased by simply putting fewer Remote Displays on EACH CABLE connected to the Model 9010 Keypad. For example, when using 18 AWG wire, you can install a maximum of seven Model 920 (2-digit) Remote Displays up to 800 feet from the Keypad on a single cable. However, if greater distance is required, simply use 16 AWG wire from the Keypad. You can now install seven Model 920 Remote Displays up to 1,300 feet from the Keypad. Distances cited are for a keypad with a 1.25A adapter.

# of Displays	Maximum Cable Distance (feet) for a 1.25A Adapter											
	Model 920		Model 9320		Model 9620		Model 930		Model 9230		Model 9430	
	18 AWG	16 AWG	18 AWG	16 AWG	18 AWG	16 AWG	18 AWG	16 AWG	18 AWG	16 AWG	18 AWG	16 AWG
1	2000	2000	2000	2000	2000	2000	2000	2000	2000	2000	2000	2000
2	2000	2000	800	1300	700	1100	2000	2000	800	1300	700	1100
3	2000	2000	400	700	300	500	1300	2000	400	700	300	500
4	1500	2000	200	400	200	400	900	1300	200	400	200	400
5	1100	1500	100	200	NA	100	600	900	100	200	NA	100
6	800	1300	NA	100			400	700	NA	100		
7	600	1100					300	500				
8	500	800					200	400				
9	400	700					200	300				
10	300	500					100	200				
11	300	400					100	100				
12	200	400					NA	100				

Note: The TOTAL CABLE LENGTH (sum of length of all cables) should not exceed 10,000 feet.

1 INSTALLATION PROCEDURES

1.1 INTRODUCTION

Save yourself some work - review Section 1 before starting installation.

This Keypad is configured to work with 9620 displays. For 9430 displays change the option "Keypad Type" to "3-Digit". See Option 2.7 in Section 3, "Keypad Options".

1.1 PRE-INSTALLATION

We recommend testing the system before installation. Connect the keypads and displays together in one room. [Short RCA cables will make setup easier.] Once you are satisfied that the system is working, proceed with your cable runs and equipment mounting.

1.2 CABLE INSTALLATION

A single cable carries both power and signal from the Keypad to Remote Displays. RCA cable may be used, but most installers find it easier to work with 2-conductor 18AWG wire. Use 16AWG wire to improve the maximum distance. Unshielded cable is acceptable. CAT 5/6 cable is not recommended, as the small wires tend to break at the Keypad. For aesthetic reasons, the installer will want to hide the cable to the displays. This can be accomplished by punching holes in the wall directly behind the displays. To support additional displays or longer cable runs than the Keypad can handle, use Booster Amp A0160.

1.3 KEYPAD INSTALLATION

The Keypad is typically wall-mounted at eye level. However, it may also be placed on a desk. Multiple keypads may be used on the same system, and will automatically communicate with each other.

1.4 KEYPAD CONNECTION

Unplug Keypad before continuing. Slide off the back cover of the Keypad and connect the 2-conductor wire. Connect the black wire to GND and the red wire to SIG. There are two terminals for both GND and SIG, allowing for two sets of wires to be connected.

CAUTION: be careful not to connect to the AUX or AC terminals. The AC terminals are used as an alternate connection point for power. This is only used with power adapters that have bare wires instead of a plug.

Once the wires are firmly connected, slide the protective cover back on and place the Keypad back into the holder.

1.5 DISPLAY INSTALLATION

The Remote Display will have optimum visibility when mounted vertically within three to four feet of eye level. This will keep the Display in the proper field of view for the observer. To hang a display on the wall, place an anchor screw into the wall, leaving the screw-head exposed. Line up the keyhole on the back of the display with the screw. Hang the display from the screw.

1.6 DISPLAY CONNECTION

Wire is fed from the wall through the cutouts on the back of the display. Connect the black wire to GND and the red wire to SIG. The additional terminals allow a parallel set of wires to carry power to the next display. Once the wires are firmly connected, hang the display back on the mounting screw(s).

1.7 TESTING YOUR SYSTEM

Once the system is wired together, plug in the Keypad and turn it on. If the Keypad shows "SHORT", then there is a short in the wiring. Turn off the Keypad and check the wiring. Otherwise, type "1", press "ENTER", and verify that "1" shows on all the displays. See the "Troubleshooting Chart" at the end of this manual for additional assistance.

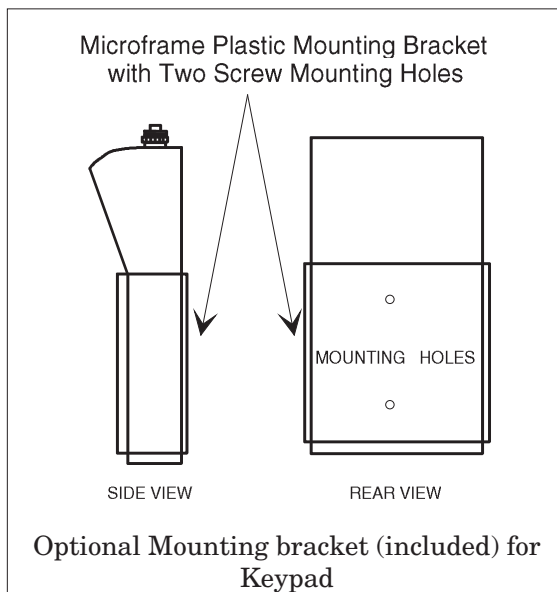

2 KEYPAD OPERATION

2.1 INSTRUCTIONS FOR USE

The Model 9010 Keypad has its own built-in, easy-to-read display so that you can see what numbers are being entered, as well as what numbers are being shown on the remote display(s).

2.2 LCD DISPLAY



1) Status

- Ready - Normal Operation
- Enter - Adding a Number
- Delete - Removing a Number
- FULL - Number List is Full

2) Number Entry Area

3) Number on Remote Display

2.3 ENTER MODE

When a number button is pressed, the Keypad will go into enter mode. The "ENTER" light will flash, and the LCD Display will show Enter in the top left-hand corner. The number currently on the Remote Display will continue to show in the upper right corner of the LCD Display while the number you are entering will show in the lower left-hand corner of the LCD Display. Continue to type number buttons until the complete number to be paged is shown. Then press "ENTER" to display the paging number on the Remote Display. When "ENTER" is pressed, the new number will be placed in sequence with any other numbers displayed on the Remote Display. If you make an error while typing a number, press "DELETE." If you attempt to enter over 32 numbers into the system, the Master Keypad "Ready" message will change to "Full" until a number is deleted.

2.4 DELETE MODE

To delete a number, press "DELETE." **The first number on the screen will be placed on the delete prompt. If this is the number to be deleted, press "DELETE" again. Otherwise, type the number to be deleted and press "DELETE."** If you make an error while deleting a number, press "ENTER."

2.5 BLINK ALERT MODE

In this mode, each number will automatically start to blink after a predetermined display time. There are two types of blinks: slow blink and fast blink.

To illustrate this feature, let's say the Slow Blink time has been set to three minutes and the Fast Blink time has been set to 5 minutes. As a restaurant example: table 14's food is ready. The number is entered into the Keypad and displayed on the Remote Displays to alert the server. After three minutes, the number 14 starts to blink slowly, meaning that table 14's food has been sitting for a little while. After 5 minutes the number 14 changes to blinking quickly, letting the server or expeditor know that table 14's food needs to be taken immediately.

2.6 MULTIPLE PAGING

The Keypad will store up to thirty-two numbers and display them sequentially until the operator deletes them.

2.7 MULTIPLE OUTPUTS

The Keypad will power multiple Remote Displays (see **Maximum Cable Length Table**).

2.8 MULTIPLE INPUTS

You may cascade up to 32 keypads on the same common cable connected to the "Signal Out" output from each Keypad. Numbers entered from each Keypad will automatically be combined and displayed in sequence with all the numbers entered from all Keypads. Each Keypad will display all numbers entered from itself as well as all numbers entered from all other Keypads at the same time they are displayed on the Remote Display(s).

Note: Keypads must be programmed as the same keypad type to work together.

2.9 POWER CONNECTION

Connect the wall mount transformer to an AC outlet and connect the power plug to the connector on the top of the Keypad marked "18-24 VAC." It is recommended that you turn the power off using the "ON/OFF" switch on the Keypad when not in use. This will greatly prolong the life of the system.

2 KEYPAD OPERATION CON'T

2.10 FUSE

The Keypad contains a fuse inside the case under the small slide-on cover. To prevent permanent damage, replace with the correct fuse. For standard keypads use a 1.6A (5mmx20mm) fast acting fuse. For keypads with a 2.5A adapter, use a 2.5A (5mmx20mm) fast acting fuse.

**WHEN REPLACING THE FUSE
BE SURE TO DISCONNECT POWER
FROM THE AC WALL OUTLET.**

2.11 OPTION CONNECTIONS

The Keypad has two optional connections on the 8-pin terminal block located under the small removable cover:

1. **AUX**—Auxiliary connection for use with the extra cost Remote Delete Option.
2. **A/C**—Remote 24 VAC Input used when a transformer other than the wall mounted one supplied with the system is required, such as an attic-mounted transformer installation.

Note: Each Keypad must operate off its own power adapter. Keypads cannot share transformers.

3 KEYPAD OPTIONS

3.1 Entering Options Mode

To enter Options Mode, do the following.

- 1) Turn on Keypad.
- 2) During the startup screen, press '0'.
- 3) "System Options" will display, signifying you are in options mode.

3.2 Options Table Summary

Options are organized as follows:

General	#1	
	Rollover	#11
	AutoDel#12	
	KeyBeep	#13
	Chime	#14
	Fact Reset	#19
Advanced	#2	
	MastSlave	#21
	Entry,Auto	#22
	Sort List	#23
	Duplicates	#24
	DeleteKey	#25
	Address	#26
	Keypad Type	#27

NAVIGATION

Type the two-digit number for the option you wish to set. The current value is shown. Type a new number to change the value. Press [ENTER] to save or [DELETE] to cancel.

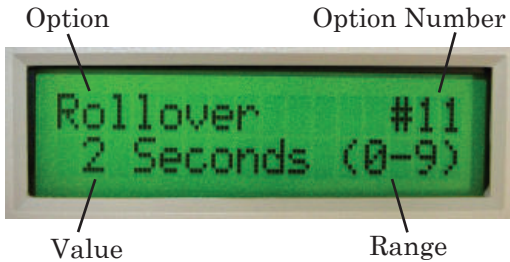

OPTIONS DEFINITIONS

1.1 Rollover

0-9 Seconds; Default 3

Rollover is the length of time a number is shown on the display before advancing to the next number in the list. A value of 0 means each number will be displayed until it is deleted.

1.2 AutoDel

0-21 Minutes; Default 0

Autodelete is the time the Keypad will hold a number before automatically deleting it. A value of 0 means autodelete is disabled.

1.3 KeyBeep

0-1 Off/On; Default 1

The audible feedback sound can be enabled or disabled.

1.4 Chime

0.0-9.9 Seconds; Default 0.3

Sets the remote display chime duration. Not all displays follow this option.

1.5 Slow Blink

0-990 Seconds; Default 90

Sets how long to wait before blinking a number slowly. This option is used to get a server's attention. A value of 0 disables this option.

1.6 Fast Blink

0-990 Seconds; Default 180

Sets how long to wait before blinking a number rapidly. This option is used to convey that attention is critically needed by a server. A value of 0 disables this option.

1.9 Factory Reset

0-1 No/Yes;

Resets all options to factory defaults.

2.1 MastSlave

0-2 Auto/Master/Slave; Default 0

This controls the master/slave arbitration on a system. There should only be one master on a system.

0 Auto – Allows the keypads to negotiate which one is the master.

1 Master – The Keypad will always be a master.

2 Slave – The Keypad will always be a slave.

2.2 Entry, Auto

0-4 None/Enter/Delete/Y/N; Default 3

This option determines number entry behavior. This can be used to set up dedicated quick-entry keypads for enter and delete.

0 None – No response to numbers typed unless user first presses [ENTER] or [DELETE].

1 Enter,N – When user types a number, Keypad assumes Enter mode. When user has typed all 6 digits, waits for [ENTER] to be pushed before adding number.

2 Delete,N – When user types a number, Keypad assumes Delete mode. When user has typed all 6 digits, waits for [DELETE] key to be pushed before deleting number.

3 Enter,Y – When user types a number, Keypad assumes Enter mode. When user has typed all 6 digits, automatically adds number.

4 Delete,Y – When user types a number, Keypad assumes Delete mode. When user has typed all 6 digits, automatically deletes number.

2.3 Sort List

0-1 Off/On; Default 1

Determines if the number list is displayed in the order entered or sorted by increasing number order.

3 KEYPAD OPTIONS CON'T

2.4 Duplicates

0-1 Disabled/Allowed; Default 0

Typically duplicate numbers are ignored. This option allows duplicate numbers to be added.

2.5 DeleteKey

0-2 Normal/QuickDel/1KeyDel; Default 1

This option adds functionality to the delete key.

0 Normal – Pressing [DELETE] brings up the delete prompt.

1 QuickDel – Pressing [DELETE] pre-populates the delete prompt with the current number being shown. Pressing [DELETE] again deletes the number. To delete a different number, type the number (it will replace the pre-populated number) and press [DELETE].

2 1KeyDel – Pressing [DELETE] deletes the number currently being shown. To delete a different number, enter the desired number, then press [DELETE].

2.6 Address

0-99; Default factory programmed

Keypad address used for Keypad to Keypad communications. Each Keypad should have a unique address.

2.7 Keypad Type

0-1 "4-Digit"/"6-Digit"; Default 0

0 4-Digit – Keypad accepts up to 4-digit numbers. Compatible with Model 920, 930, 940, 941 and 942 Displays.

1 6-Digit – Keypad accepts up to 6-digit numbers. Compatible with Model 960 Displays.

Song Mode

If the user would like to use the Keypad to show hymn numbers in a song service, the following steps should be taken:

- 1) Program the Rollover Time (1.1) to 0.
- 2) Program the Sort Option (2.3) to 0.
- 3) Program the DeleteKey Option to 2.

After these options have been programmed, enter the hymn numbers in the order in which they will be displayed. At the end of each hymn, press [DELETE]. The next hymn number will be displayed.

4 DISPLAY OPERATION

4.1 POWER

Remote Displays are powered by the Keypad. Thus, when the Keypad is turned off, the Remote Displays are also powered off.

4.2 MAXIMUM NUMBER OF DISPLAYS

See **Maximum Cable Length Chart** to determine how many displays the Keypad can support, or call Microframe technical support for assistance.

The Model 160 Boaster Amp may be added to power additional displays.

4.3 SYSTEM SIGNAL CONNECTION

Refer to **Connection Diagrams** for details.

For 16 or 18 AWG paired wire installations, use the two-conductor terminal block located on the back of the display. Be careful to observe **SIGNAL** and **GROUND** polarity. There is a second set of connectors to use if running another wire to the next Display.

If you are using RCA connectors, then connect the coaxial cable to either "**Signal**" connector on the remote display. To add a second Remote Display, connect one end of the signal cable to the other RCA phono connector on the first Remote Display and the other end to either connector on the next Remote Display.

EXPLANATION OF ERROR CODES

There are five error conditions that will cause an Error Code to appear on the Model 9010 Keypad display. It will be of great assistance in troubleshooting the system if you will note the displayed code when calling for assistance. For technical support call 1-800-635-3811.

ERROR MESSAGE	CAUSE
Short	The cable is shorted between the Keypad and the Display.
StuckHi	The Keypad output is damaged or there is another device on the line holding it high.
NoInts	Master or Slave Keypad is not getting the interrupts it needs to work.
EEfail	Keypad is unable to remember settings.
CommErr	Communication error.

TROUBLESHOOTING CHART

SYMPTOM	POSSIBLE CAUSE	CURE
Keypad is dark and unresponsive	Keypad is not receiving power.	Check that Keypad is plugged in. Is the AC outlet working? Is the Keypad fuse blown? Is the Keypad power switch on?
Keypad displays SHORT	There is a short across the output of the Keypad.	Does disconnecting the signal cable solve the issue? If so, the problem is in the cable.
Keypad displays StuckHi	Keypad is unable to send data on the line.	Does disconnecting the signal cable solve the issue? If not, the Keypad is damaged and needs service.
Keypad displays NoInts	The wrong power adapter is in use. The Keypad is in slave mode without a master, or the Keypad is damaged.	Does the power adapter have an output of 24VAC, 1.2A? Set Keypad programming to 'Auto' or connect to a master. If damaged, return Keypad for service.
EEfail	Keypad cannot remember settings.	Keypad is damaged. Return for service.
CommErr	Communication Error.	Verify programming to make sure only one Keypad is a master. Check wiring between Keypads. Check for strong interference next to signal cable.
Keypad works but does not light up or has erratic numbers	Poor signal connection to Remote Display.	Does the display work when connected to the display with a short (i.e. 3 ft) piece of cable? If so, the problem is in the wiring.

CAUTION: Always unplug power before connecting/disconnecting the signal cable or changing the fuse.

microframe[®]

Microframe Corporation
604 S. 12th Street
Broken Arrow, OK 74012

Tel: (918) 258-4839
Toll Free: 1-800-635-3811
Website: www.microframecorp.com
E-mail: support@microframecorp.com



MODEL 9010 SPECIFICATIONS

Keypad

Features

This keypad displays four or six sets of numbers at a time on the LCD screen. The low profile membrane keypad and ABS plastic case fits snugly into the included wall mount bracket.

Operation

Page servers or guests with this multi-number keypad. Numbers entered on this keypad will be displayed on remote displays.

In 2-Digit mode the keypad will show 6 sets of numbers at a time. This mode is compatible with 920, 9320, and 9620 displays.

In 3-Digit mode the keypad will show 4 sets of numbers at a time. This mode is compatible with 930, 9230, and 9430 displays.



Microframe® Model 9010 Keypad

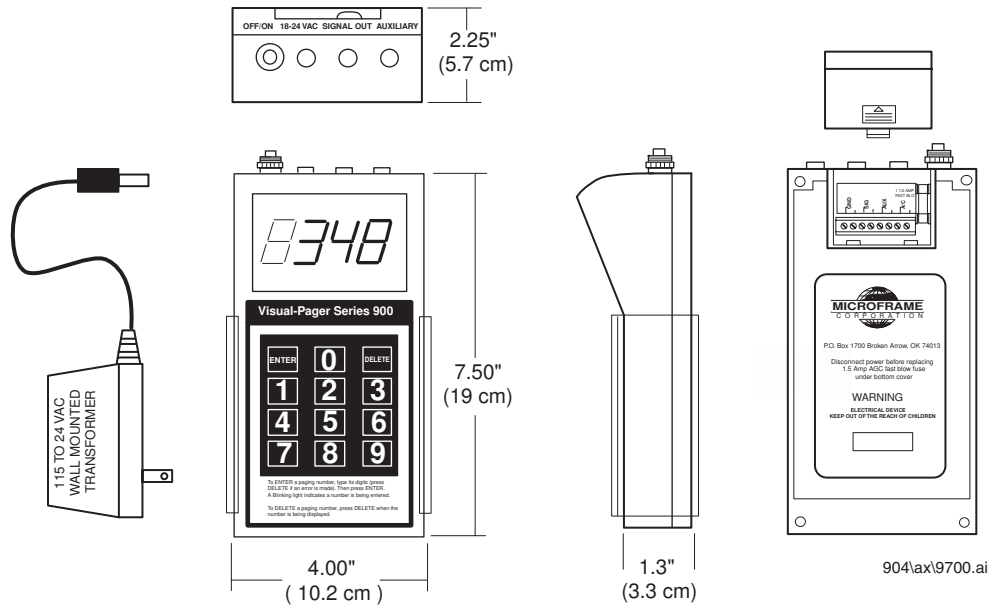

Model 9010 Specifications

Local Keypad Display	Backlit LCD screen
Maximum Numbers Stored	32 numbers
Maximum Keypads in System	32 keypads
Input Power	115 VAC into power adapter
Power Adapter	24 VAC, 1.2A standard, 2.5A optional
Line Frequency	50 or 60 Hz
Fuse Requirements	1.6A fast-acting fuse (5mm x 20mm) or 2.5A
Weight	0.75 lb (0.4 kg), with transformer 2.25 lb (1.0 kg)

Sales and Support
1-800-635-3811

Microframe® Corporation
 P.O. Box 1700
 Broken Arrow, OK 74013
www.microframecorp.com



MODEL 920 SPECIFICATIONS

Remote Display

Features

The Model 920 Display has 5.5 inch tall digits viewable up to 125 feet and is encased in an aluminum extruded case. The Remote Display works with the Microframe Model 9010 Keypad. The Remote Display receives signal and power from a single cable connected to the Keypad and is turned on or off with the Keypad power switch.

Operation

The Model 920 Remote Display is designed to show a single 2-digit number at a time. Optional ceiling mounts are available in a single, double, or triple cluster for easy mounting in the center of or around the peripheral of a large retail area. Outdoor displays are also available.



Microframe® Model 920 Display

Front View

Extruded Aluminum with Red Plexiglass Faceplate

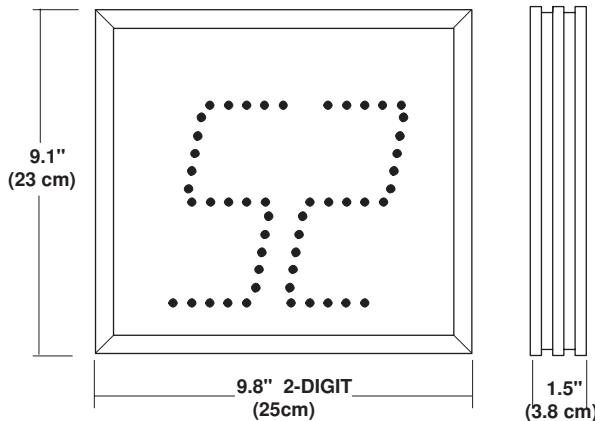

Back View

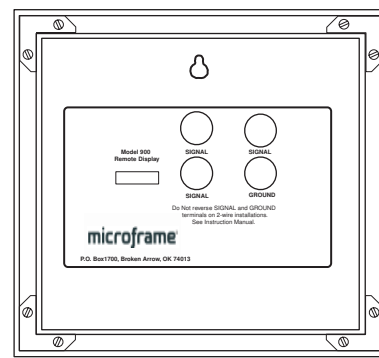

4100\ax\9700.ai

Model 920 Specifications

Remote Display	Wall mount red LED display
Power Input Requirements	Powered by Keypad
Character Height	5.5 inches (14 cm)
Character Viewing Distance	125 feet in indoor light
Case	Aluminum case with Plexiglas faceplate
Weight	2-digit, 2.5 lbs (1.1 kg)

Sales and Support
1-800-635-3811

Microframe® Corporation
 P.O. Box 1700
 Broken Arrow, OK 74013
www.microframecorp.com



MODEL 9320 SPECIFICATIONS

Remote Display

Features

The Model 9320 Remote Display is designed to show up to three 2-digit numbers at a time. The Model 9320 Display has 5.5 inch tall digits viewable up to 125 feet and is encased in an aluminum extruded cabinet. Optional ceiling mounts are available in a single, double, or triple cluster for easy mounting in the center of or around the peripheral of a large retail area. Outdoor displays are also available.



Microframe® Model 9320 Display

Operation

The Model 9320 Remote Display is designed to operate with the Microframe Model 9010 Keypad. The signal and power is received from a single cable connected to the Keypad. Up to four displays may be connected directly to the Keypad.

Front View

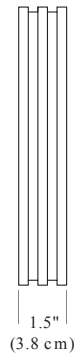
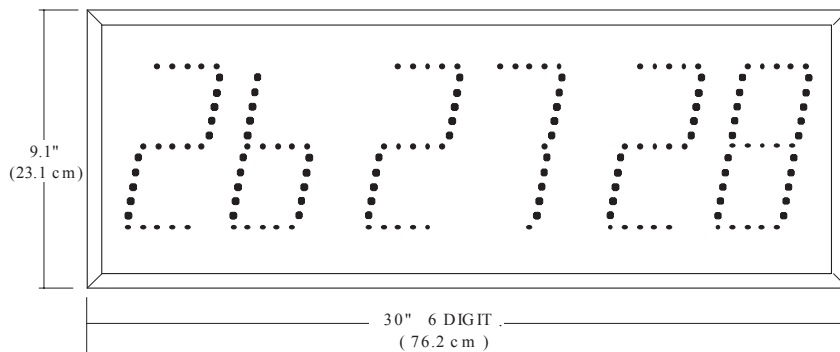

Back View

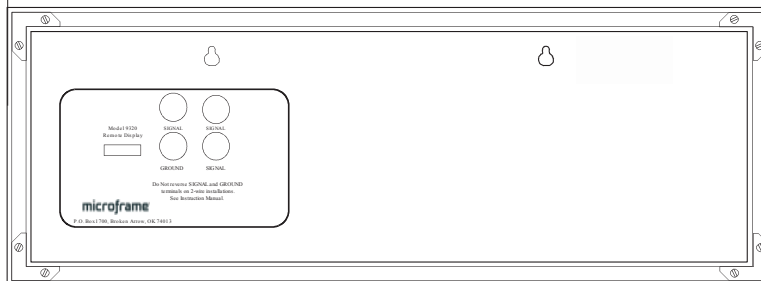

GA W.9320, AX: 9700

Model 9320 Specifications

Remote Display	Wall mount red LED display
Power Input Requirements	Powered by Keypad
Character Height	5.5 inches (14 cm)
Character Viewing Distance	125 feet in indoor light
Case	Aluminum case with Plexiglas faceplate
Weight	5.5 lbs (2.5 kg)

Sales and Support
1-800-635-3811
 Microframe® Corporation
 P.O. Box 1700
 Broken Arrow, OK 74013
www.microframecorp.com



MODEL 9620 SPECIFICATIONS

Remote Display

Features

The Model 9620 Remote Display is designed to display up to six 2-digit numbers at a time. The Model 9620 Display has 2.5 inch tall digits viewable up to 80 feet and is encased in an aluminum extruded cabinet. Optional ceiling mounts are available in a single, double, or triple cluster for easy mounting in the center of or around the peripheral of a large retail area. Outdoor displays are also available.



Microframe® Model 9620 Display

Operation

The Model 9620 Remote Display is designed to operate with the Microframe Model 9010 Keypad. The signal and power is received from a single cable connected to the Keypad. Up to four displays may be connected directly to the Keypad.

Front View

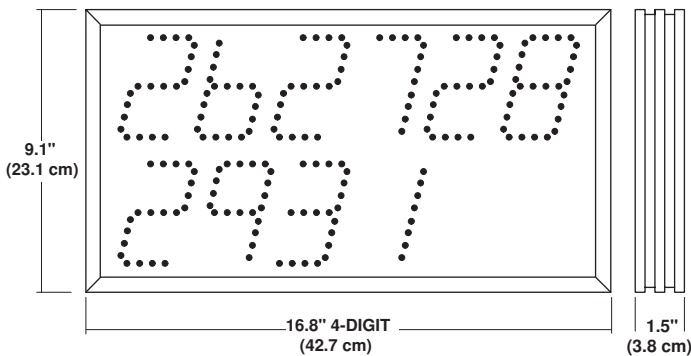

Back View

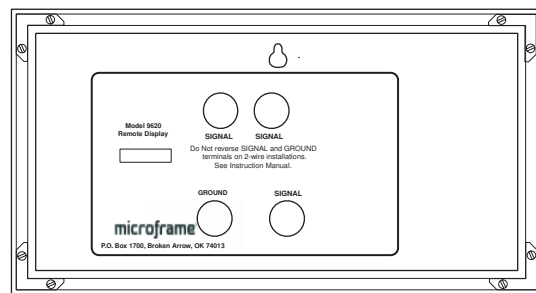

4600\AX\9700.ai

Model 9620 Specifications

Remote Display	Wall mount red LED display
Power Input Requirements	Powered by Keypad
Character Height	2.5 inches (6.4 cm)
Character Viewing Distance	80 feet in indoor light
Case	Aluminum case with Plexiglas faceplate
Weight	3.5 lbs (1.6 kg)

Sales and Support
1-800-635-3811

Microframe® Corporation
 P.O. Box 1700
 Broken Arrow, OK 74013
www.microframecorp.com



MODEL 930 SPECIFICATIONS

Remote Display

Features

The Model 930 Remote Display is designed to show a single 3-digit number at a time. The Model 930 Display has 5.5 inch tall digits viewable up to 125 feet and is encased in an aluminum extruded cabinet. Optional ceiling mounts are available in a single, double, or triple cluster for easy mounting in the center of or around the peripheral of a large retail area. Outdoor displays are also available.

Operation

The Model 930 Remote Display is designed to operate with the Microframe Model 9010 Keypad to provide a continually refreshed Remote Display of up to 32 different 3-digit numbers from 000 to 999. The signal and power is received from a single cable connected to the Model 9010 Keypad. Up to 11 displays may be connected directly to the Model 9010 Keypad.

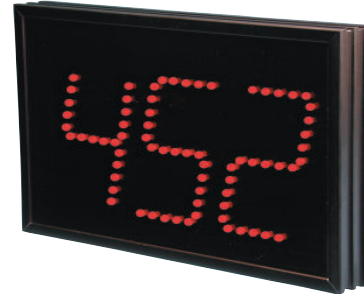

Microframe® Model 930 Display

Front View

Back View

Red Plexiglas with Extruded Aluminum Frame

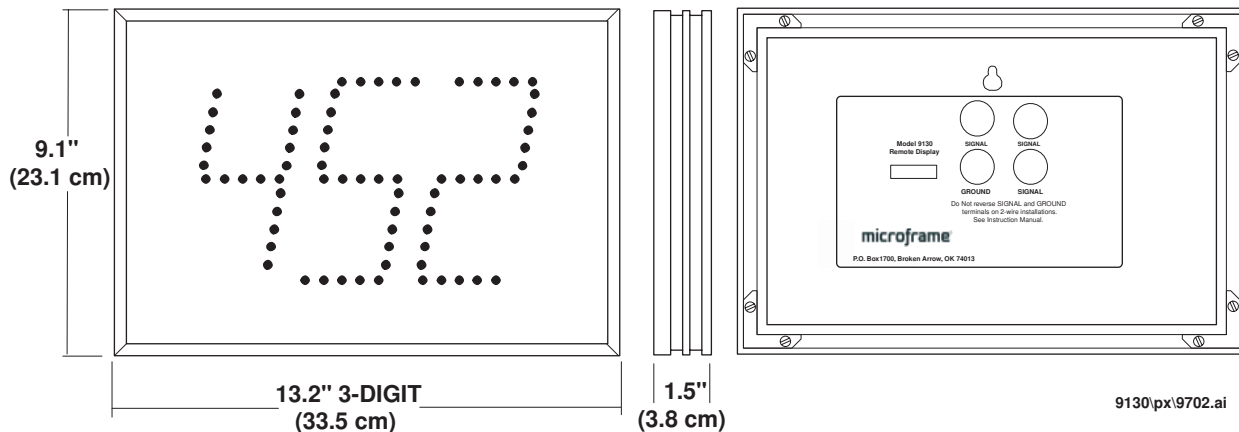

Model 930 Specifications

Remote Display	Wall mount red LED display
Power Input Requirements	Powered by Keypad
Character Height	5.5 inches (14 cm)
Character Viewing Distance	125 feet in indoor light
Case	Aluminum case with Plexiglas faceplate
Weight	3.0 lbs (1.4 kg)

Sales and Support
1-800-635-3811

Microframe® Corporation
 P.O. Box 1700
 Broken Arrow, OK 74013
www.microframecorp.com



MODEL 9230 SPECIFICATIONS

Remote Display

Features

The Model 9230 Remote Display is designed to show up to two 3-digit numbers at a time. The Model 9230 Display has 5.5 inch tall digits viewable up to 125 feet and is encased in an aluminum extruded cabinet. Optional ceiling mounts are available in a single, double, or triple cluster for easy mounting in the center of or around the peripheral of a large retail area. Outdoor displays are also available.

Operation

The Model 9230 Remote Display is designed to operate with the Microframe Model 9010 Keypad to provide a continually refreshed Remote Display of up to 32 different 3-digit numbers from 000 to 999. The signal and power is received from a single cable connected to the Model 9010 Keypad. Up to four displays may be connected directly to the Model 9010 Keypad.



Microframe® Model 9230 Display

Front View

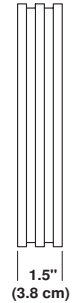
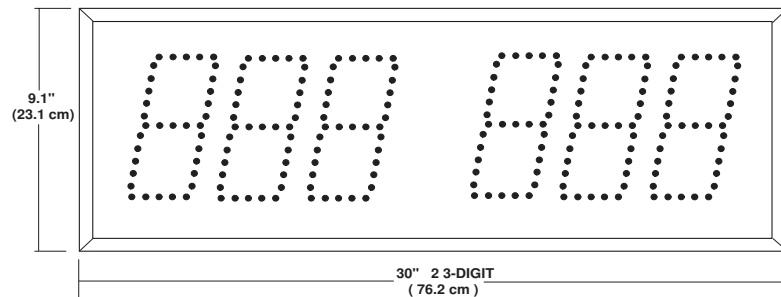

Back View

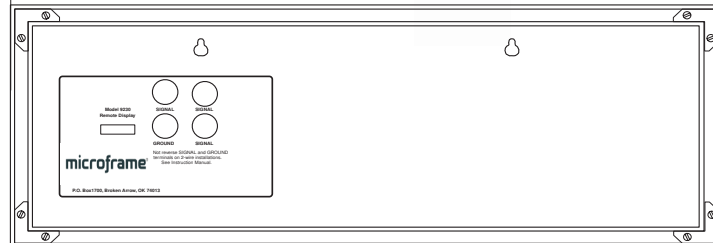

9230(px)9701.ai

Model 9230 Specifications

Remote Display	Wall mount red LED display
Power Input Requirements	Powered by Keypad
Character Height	5.5 inches (14 cm)
Character Viewing Distance	125 feet in indoor light
Case	Aluminum case with Plexiglas faceplate
Weight	6 lbs (1.6 kg)

Sales and Support
1-800-635-3811

Microframe® Corporation
 P.O. Box 1700
 Broken Arrow, OK 74013
www.microframecorp.com



MODEL 9430 SPECIFICATIONS

Remote Display

Features

The Model 9430 Remote Display is designed to show up to four 3-digit numbers at a time. The Model 9430 Display has 2.5 inch tall digits viewable up to 80 feet and is encased in an aluminum extruded cabinet. Optional ceiling mounts are available in a single, double, or triple cluster for easy mounting in the center of or around the peripheral of a large retail area. Outdoor displays are also available.

Operation

The Model 9430 Remote Display is designed to operate with the Microframe Model 9010 Keypad to provide a continually refreshed Remote Display of up to 32 different 3-digit numbers from 000 to 999. The signal and power is received from a single cable connected to the Model 9010 Keypad. Up to four displays may be connected directly to the Model 9010 Keypad.



Microframe® Model 9430 Display

Front View

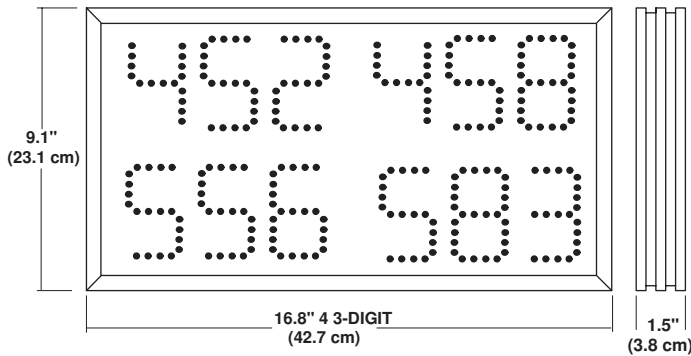

Back View

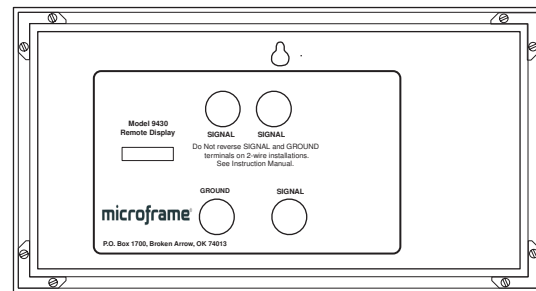

9040/px\9700.ai

Model 9430 Specifications

Remote Display	Wall mount red LED display
Power Input Requirements	Powered by Keypad
Character Height	2.5 inches (6.4 cm)
Character Viewing Distance	80 feet in indoor light
Case	Aluminum case with Plexiglas faceplate
Weight	3.5 lbs (1.6 kg)

Sales and Support
1-800-635-3811

Microframe® Corporation
 P.O. Box 1700
 Broken Arrow, OK 74013
www.microframecorp.com