

Microframe Corporation

Series: 5400

Jump to Quick Starts



Take-A-Numberp.6



Time-of-Day Clocksp.7



Countdown Timerp.8



Count Up Timer.....p.8

Operating Manual

A5400-7019



Limited Warranty Agreement

Your Microframe System is warranted against failure due to defects in workmanship or material for a period of one (1) year from the date of purchase. Microframe Corporation will repair or replace any defective unit. Obvious abuse or mishandling of the unit is NOT covered by this warranty.

Merchandise Return

If your Unit does not work satisfactorily, please give us a call. We may be able to clear up the problem by phone. If it becomes necessary to return your Unit to the factory, please observe the following:

1. Place Unit in a sturdy box with sufficient packing material.
2. If requested, include the AC power adapter. It is not necessary to return the cable and connectors unless they are the problem.
3. Return the system insured and prepaid since we are not responsible for shipping damages and losses on returned Units.

Warranty Service

For warranty service, please contact Microframe toll-free at (800) 635-3811. A technician will gladly assist you.

Assistance

For any product assistance or maintenance help, contact Microframe by either calling 1-800-635-3811 or e-mailing us at: support@microframecorp.com.

Safety

Do not install substitute parts or perform any modification to the product without first contacting Microframe.

Warning

All power adapters, line cords, and electrical equipment should be kept out of the reach of children and away from water. (If you are installing cable in an air plenum area, such as a drop ceiling used for air return, you must use plenum-rated cable. The cable supplied from Microframe is rated CL2 and is approved for installation everywhere indoors except plenum areas.)

Life Support Policy

Microframe's products are not authorized for use as components in life support devices or systems without the express written approval of the president of Microframe Corporation.

As used herein:

1. Life support devices or systems are defined as systems which support or sustain life, and whose failure to perform when properly used in accordance with instructions for use provided in the labeling, can be reasonably expected to result in a significant injury to the user or any one depending on the system.
2. A critical component is any component of a life support device or system whose failure to perform can be reasonably expected to cause the failure of the life support device or system, or to affect its safety or effectiveness.

Disclaimer

We are constantly striving to improve our products. Due to this, specifications are subject to change without notice.



SERIES 5400

INSTALLATION & SPECIFICATION GUIDE

ITEM NO: A5400-7019
REVISION DATE: 09/07

Microframe Corporation
604 S. 12th Street
Broken Arrow, OK 74012

Tel: (918) 258-4839
Toll Free: 1-800-635-3811
Website: www.microframecorp.com
E-mail: support@microframecorp.com

Table of Contents

How to Use this Manual and the Remote Control	5
Take-A-Number System Quick Start Instructions	6
Time-of-Day Clock Quick Start Instructions	7
Count Up/Countdown Timer Quick Start Info	8
Wiring Diagrams	9
Multiple AC Adapter Connection Detail Info	10
Optional External Chime Connection Detail Info	10
Using Multiple Displays	11
Understanding the Programmable Options	12
Setting the Programmable Options	14
Options Table.....	15
Multi-Window Service System (MWSS)	16
Model 5400 Specifications.....	19
Stand-Alone Displays	19
Timer/Clock Troubleshooting Chart	20
General Troubleshooting Chart	20
Take-A-Number Troubleshooting Chart	20
Remote Control Troubleshooting.....	20
5400 Remote Display Mounting Template.....	21

How to Use this Manual and the Remote Control

Congratulations on your purchase of the Microframe Model 5400 display. This display can be used as a Take-A-Number/Counter System, a Clock, or a Count Up/Down Timer.

Manual Organization

Realizing that most users are only interested in one of these modes, we have made "Quick Start Instructions" for each of the three applications. Users with only one display per installation and no special requirements should be able to connect and run their displays by reading only the "Quick Start" page pertaining to their application.

Quick Start Sections are as follows:

- * Take-A-Number System -----Page 6
- * Time-of-Day Clock -----Page 7
- * Count Up/Down Timer-----Page 8

For more advanced wiring needs, see the "Wiring Diagrams" on pages 9 and 10.

If you have multiple displays, see "Using Multiple Displays" on page 11.

To custom-configure your displays, see "Understanding the Programmable Options" on pages 12 and 13 and "Setting the Programmable Options" on pages 14 and 15.

To understand the advanced Multiple Window Service System, read the description of "Multi-Window Service System" on pages 16, 17 and 18.

For a spec sheet, see page 19

For troubleshooting needs, see page 20

For mounting templates, see page 21.

Definition of Terms

Programming Buttons: These are the three function buttons on the back of the Model 5400 display designed to program your system and are labeled Mode, Advance and Increment.

Push Buttons: These are the buttons that you may wire to the back of the display to control the display's functions.

Remote Control: This is the 'TV' style remote control which you may purchase as an option with your display to program and/or operate your system.

Legends

Remote Control Instructions

When reading the programming instructions for the remote control, the buttons on the remote are enclosed with "quotes" and items shown on the display are enclosed in (parentheses).

Remote Control Overview

The following is a summary of the remote control's functionality utilized by this display:

Clear

- resets the number to zero in Take-A-Number (TAN) mode
- resets to zero or reload time in Timer mode

Up/Down

- increment or decrement the current number in TAN mode
- start/stop the timer in timer mode
- go through choices in programming mode

Enter

- accept/enter an entry

Exit

- cancel an entry
- hold for 5 seconds to activate Remote Lockout (see programmable option L)

Menu

- puts the display in programming mode.

The system works with most Philips (RC5) remotes.

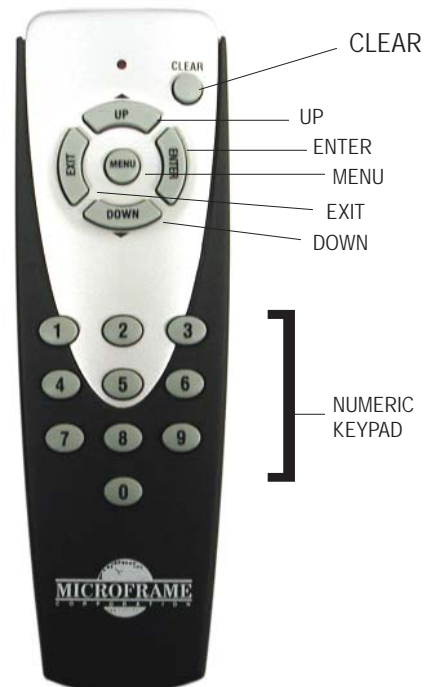

Take-A-Number System Quick Start Instructions

The 5400 system is preset at the factory to work as a Take-A-Number system. Simply make the connections as described below, read the brief operating instructions, and you should be ready to go.

Installation Instructions

(Please refer to diagram below for further details)

Step 1: Screwdown Connectors

All push button/wire connections to the 5400 Series displays are made with screwdown terminals located on the back of the display. To use "screwdown terminals," simply push the stripped wire into the hole in the side of the connector and then tighten the screw onto the wire with a screwdriver.

Step 2: Connecting Push Buttons

Typical Take-A-Number systems use push buttons wired to the display to increment and decrement the "Now Serving" number. If you have purchased a remote control, you may find that you do not need these buttons.

To connect the push buttons, connect one wire from each button under the screwdown terminal labeled "Common." Place one of the remaining wires under "Input 1" terminal and the other under "Input 2" (see diagram below). Pushing the button connected to "Input 1" increments the display, and pushing the button connected to "Input 2" decrements the display.

Step 3: Connecting Power

Each 5400 Series display includes an AC power adapter. **With the power adapter unplugged from the wall outlet**, connect the wires from the power adapter to the screwdown terminals labeled "24 VAC."

Step 4: Powering the Display

Plug in the power adapter to an AC outlet. The system should now be operational.

Step 5: Hanging the Display

The 5400 Series displays hang on the wall like a picture. Depending on your installation, you may want to run the wires to the display in a wall or raceway for aesthetic purposes.

Operating Instructions

Count Up

Push the button wired as the "count up" button or push the "UP" button on your remote control.

Countdown

Push the button wired as the "countdown" button or push the "DOWN" button on your remote control.

Quick Set

If you have a remote control, enter the desired number on the remote and then press the "ENTER" button to accept that number. If you only have push buttons, push and hold the "Count Up" button until the 10's digit begins to blink. You may now use the count up button to change the 10's digit, or continue holding the button down until the next most significant digit on your display begins to blink. You can use this method to set all of the digits on your display.

Reset to Zero

If you are using the remote control, press the "CLEAR" button to reset the displays to zero. If you have a "Count Up" and "Countdown" push button connected, then pushing them both at the same time will cause the display to reset to all zeros.

Chime

The 5400 Series displays are equipped with an internal chime. This will sound every time a number is changed. To disable the chime from a remote control, follow this procedure: Press "Menu" on the remote. The display will show (-1). Press "UP" until the display shows (-6) then press "ENTER." The display will show (00). Press the "UP" button until the display shows (Jx) where "x" is any number. Press "0" then "ENTER." The chime is now disabled. If you do not have a remote control, please read the programming instructions.

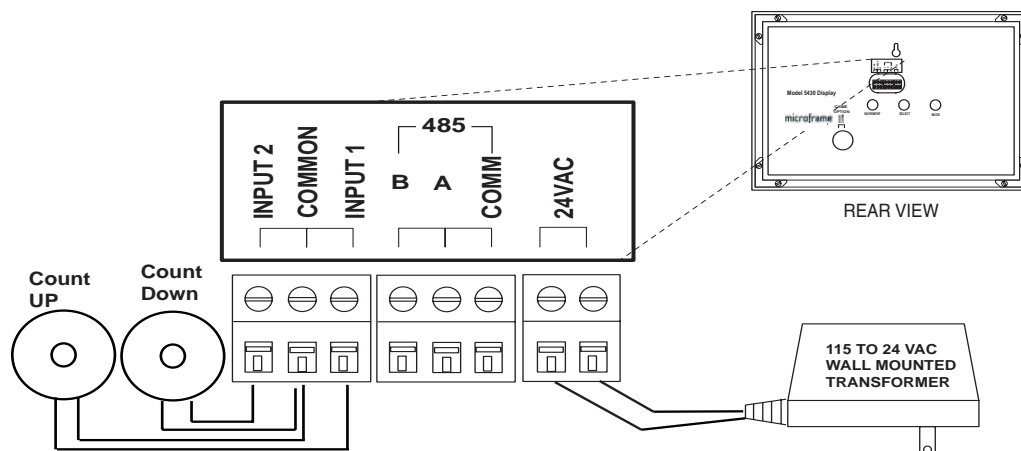

Time-of-Day Clock Quick Start Instructions

The Model 5400 Series display can be configured to show the time of day. Multiple slave displays can be configured to all show the exact same time. All displays can be reset from the master clock.

Step 1: Connect External Push Buttons

If you desire to set the time on the display without taking the display off the wall, you will want to connect two push buttons to the display or use the remote control. To connect the push buttons, simply place one wire from each push button under the screwdown terminal labeled "Common" and the remaining two wires under "Input 1" and "Input 2." (See diagram below.)

Step 2: Plug in the Power Adapter

Plug in the power adapter to an AC outlet. The display should now be operational and show all zeros.

Step 3: Set the Display to be a Clock

Manually (use function buttons on the back of the display)

- Press the "mode" button once.
- Then press the "advance" button until the display shows "00."
- Press the "select" button once.
- The display automatically exits the program mode. Colons will be flashing and a time will be on the display.

Remote Control

- From a remote control, press "MENU." The display will show (-1).
- Press the "UP" button until you reach (-3), then press "ENTER" to accept.

NOTE: When the display loses power, the time will be reset to 12:00.

Step 4: Set the Display Time

There are three ways to set the time:

A. From the back of the display.

- While holding the "select" button, press the "mode" button to increment the hours.
- While holding the "select" button, press the "advance" button to increment the minutes.
- Press the "advance" button to zero the seconds. (Do not hold the "select" button.)

B. From push buttons.

- If you connected push buttons to "inputs 1 and 2," then by pushing the button connected to "input 1" will set the hours and "input 2" will set the minutes.

C. From remote.

- Enter the time and press the "ENTER" button. Note you must enter seconds (hh:mm:ss) even if your display is less than 6 digits.

Installation

The 5400 Series displays hang on the wall like a picture. Most installations hide the wire in the wall or in a raceway.

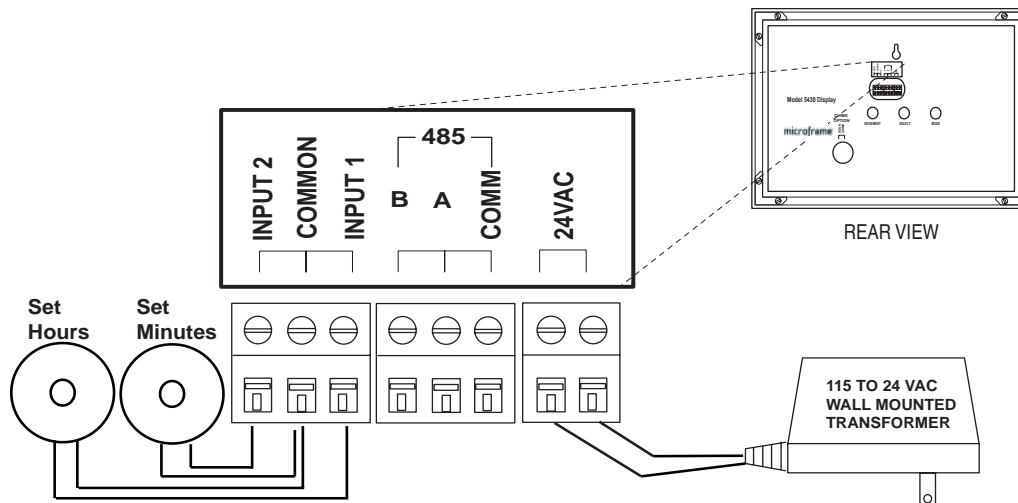

Count Up/Countdown Timer Quick Start Info

Count Up/Countdown Timer

Step 1: Connecting Start/Stop Buttons

Push buttons connected to "Inputs 1 and 2" can be used to start/stop and reset the timer. If you have purchased a remote control, you may find that you do not need these buttons. To connect the buttons, simply run the wire pair from each button to the screwdown terminals on the back of the display. Connect one wire from each button under the screwdown terminal labeled "Common." Place one of the remaining wires under "Input 1" terminal, and the other under "Input 2." (See diagram below.)

Step 2: Connect Display Power

Using the supplied AC power adapter, connect the power to the display. (See diagram below.)

Step 3: Plugging in the Power

The display(s) should turn on and show all zeros.

Installation

The 5400 Series displays hang on the wall like a picture. Most installations hide the wire in the wall or in a raceway.

Set Display to Timer Mode

Step 1: Set the Display to Count Up/Down Mode

From the Program Button

- Press the "mode" button one time.
- To program the display to be a count up timer, press the "advance" button until the display shows "01."
- To program the display to be a countdown timer, press the "advance" button until the display shows "02."
- Press the select button.
- The display is now programmed.

OR

Using the remote control, press the "MENU" button. Then press "UP" until you see "-2." Then Press "ENTER."

Controlling the Timer

By default, using the button connected to "Input 1" will start and stop the display. The button connected to "Input 2" will clear or reset the display. To change the default function of the push buttons, see the detailed programming section.

OR

Using the remote control, press "UP" as a start/stop for count up, or "DOWN" to start/stop countdown. Pressing "CLEAR" on the remote will clear a display that is counting up or cause the display to reload the "Start Time" if the display was counting down.

Setting the Time

Using the remote control, simply type in the time and press "ENTER." If you do not have a remote, you must set the start time using the three programming buttons on the back of the display. To do this, see "Setting the Time" in the programming section of the manual.

Setting the Reload Time

Using the remote control press the "MENU" button. Then press "UP" until you see (-4) then press "ENTER." Next, type in the desired start time and press "ENTER." When the display counts down to zero, it will reload this time and stop. If you do not have a remote control, see the "Setting options without remote" section of the manual.

Setting the Chime Time

Using the remote control, press the "MENU" button. Then press "UP" until you see (-5), then press the "ENTER" button. Next, type in the desired "chime time" and press "ENTER." Any time the display counts past this time, it will chime.

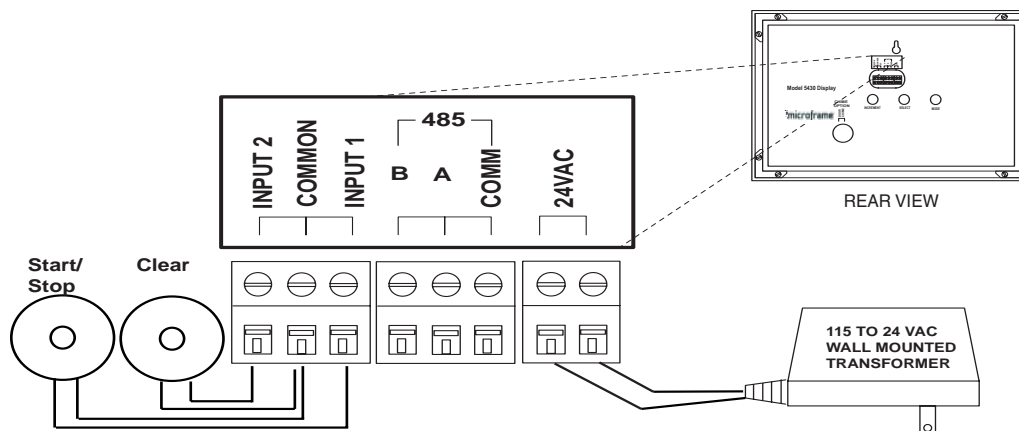

Wiring Diagrams

Study the wiring diagram below and on the next page for details on how to connect the various elements of your system. These connections apply to displays used in all programming modes.

The diagram below shows a multiple display system running off of one adapter. Although the drawings only show buttons connected to one display, you may connect buttons to each display in the system, depending on your application.

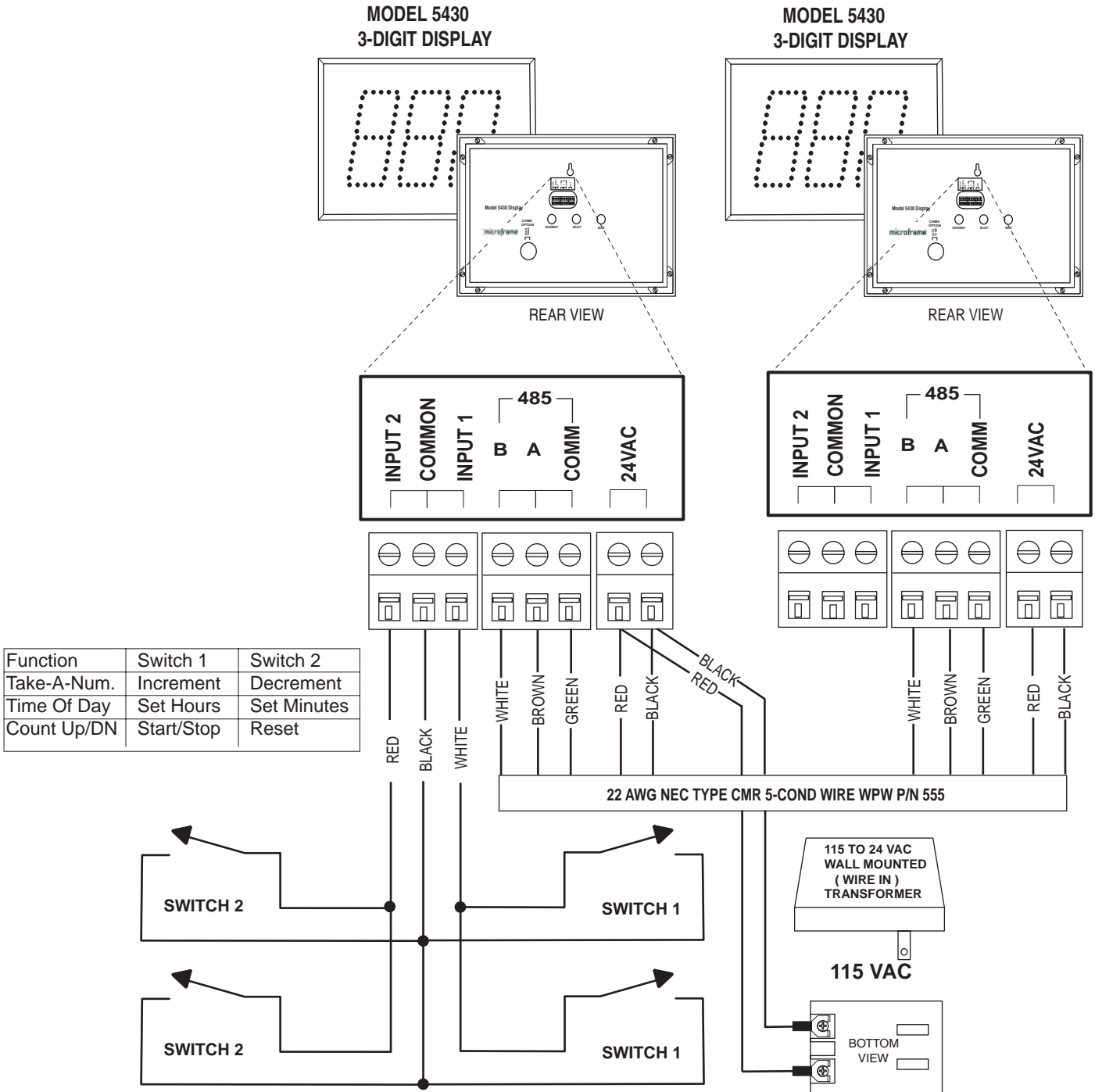

5400px19701.ai

Wiring Diagrams -Continued-

Multiple AC Adapter Connection Detail Info

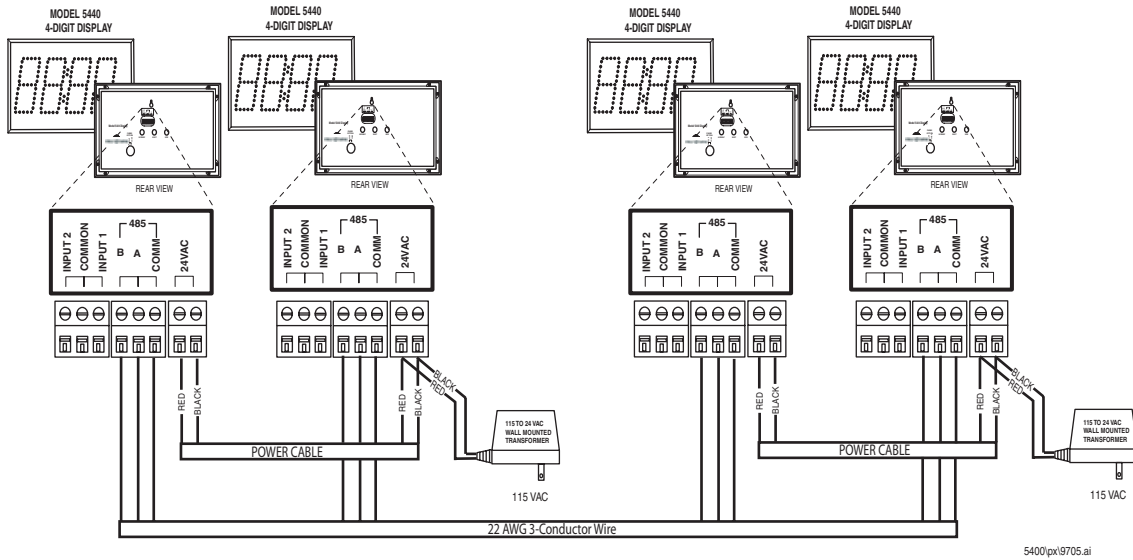

Optional External Chime Connection Detail Info

Model 5400 Remote Display

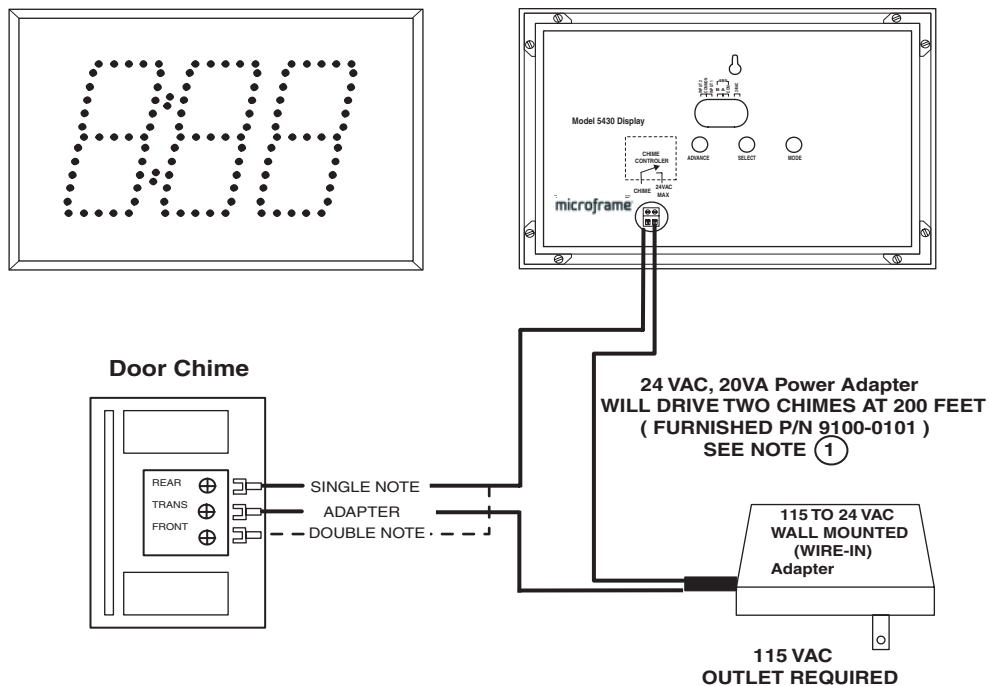

Using Multiple Displays

Introduction

The 5400 Series displays have been designed to be capable of working together in large systems. The electrical connections for multiple displays have been shown in the wiring diagrams on the previous pages which is the same for connecting multiple displays, regardless of the application.

Depending on your application, you may have to set the mode of additional displays to operate as "slaves." The specifics for using multiple displays with each mode are outlined below.

Take-A-Number System (Standard)

To have multiple displays all showing the same number in a Take-A-Number system, simply connect the displays as shown in the electrical connection diagrams. You may wire push buttons to any of the displays in the system. Pushing the buttons connected to any of the displays will cause the numbers to change on all of the displays. **No programming is necessary for this option.**

Time-of-Day Clock and Count Up/Down Timers

To use multiple displays with these systems, you will need to set one display in the system to either a Clock (as outlined in the "Clock Quick Start" instructions) or a timer (as outlined in the "Timer Quick Start" instructions). All additional displays will need to be set as "Slaves." To set a display to slave mode, you will need to use the programming buttons on the back of the display or the remote control as outlined below. All "slave" displays will show the same numbers as the master. **Remote push buttons connected to slaves will not function. Only the remote control or push buttons used on the master display can change the time on the slave displays.**

Set as Slave using Remote Control

From the remote control, press "MENU." The display will show

(-1). Press "UP" until you reach (-6) then press "ENTER." The display will show (00). Now press "UP" one time, then type 3, then "ENTER."

Set as Slave using Programming Buttons

- Press the "mode" button twice.
- Press the "advance" button until the display shows "13."
- Press and hold the "mode" button until the display returns to normal. Colons will begin to flash.

Multi-Window Service System

A Multi-Window Service System is basically a Take-A-Number system with the ability to have displays over multiple service counters. Each service counter display can show the number of the customer that is actually being served rather than the highest number. Because this is a complex configuration, there is an entire section of the manual dedicated to this topic. Please see "Multi-Window Service Systems" for further information.

Understanding the Programmable Options

Introduction

Customers with standard Take-A-Number, Clock or Count Up/Down systems will not need to read this section of the manual. All of the programming for 90 percent of the applications are specified on the quick start pages for the particular application. This section should be read by those customers desiring to change the standard behavior of the display or to utilize the advanced features of the display. The first step in programming the displays is understanding the programmable options. This section will include a definition of what each option will do. The final step is to understand how to set the features on the display (see "Setting the Programmable Options").

Organization

The memory for the 5400 Series displays is organized into "areas." The "areas" are numbered 1-9 and then A-J. Each "area" contains a 1-digit value from 0-9. For instance, "area B" could be set to 4. The 5400 display looks at the values stored in its memory to determine its behavior. In the following pages, the meaning of the values stored in each area will be discussed in detail as they pertain to each of the three modes (Take-A-Number, Clock and Timer). In addition to these memory locations, areas U, V and Y are used to store 6-digit times for purposes discussed below.

It makes the most sense to study the memory locations organized by functions as seen below. To view memory by location, see the "Programmable Options Summary Sheet" on the following pages.

Overall Mode of Display

Area 1 - Mode

The display looks at this area of memory to determine what type of display it is; i.e. Clock, Take-A-Number, Count Up/Count-down, etc.

- 0 - Clock
- 1 - Count Up Timer
- 2 - Countdown Timer
- 3 - Slave Display (Clock or Timer)
- 4 - MWSS Lobby Master
- 5 - MWSS Lobby Slave
- 6 - MWSS window slave auto address
- 7 - MWSS clerk slave manual address

Button Logic (Affects all Modes)

These options effect how the display "Inputs 1 and 2" respond.

Area 9 - Dry/Voltage Input

0 - If Area 9 is set to a 0, then the push buttons will respond when the inputs are shorted together. No external voltage should be applied with the inputs in this state.

1 - If Area 9 is set to a 1, then the push buttons will respond to a TTL level signal between the input and "common."

NOTE: "Common" should be tied to ground.

Area A - Normally Open/Normally Closed

0 - With the value set to zero, the display will assume that the normal state of the inputs is not shorted together.

1 - With the value set to 1, the display will assume that the normal state of the inputs is shorted together or +5 volts if Area 9 is set to 1.

Area C - Momentary vs. Continuous

0 - With the value set to zero, the display will expect a momentary contact closure at its inputs; i.e. a doorbell push button.

1 - With the value set to 1, the display will treat the buttons as "change of state;" i.e. it will trigger an event when the signal changes from shorted to open and vice versa.

Area L - IR Lockout

0 - Display will ignore the remote (prevents accidental changes to display in a multi-display installation).

1 - Display will respond to remote.

You may also toggle IR Lockout on/off by pressing and holding the exit button for 5 seconds. The display will indicate the change by showing "0ir" or "1ir," where "0"=locked and "1"=normal.

Clock and Timer Features

These options pertain to the Clock or Timer modes of the display only.

Area 2 - On Roll Over

If the display is counting up and reaches its roll over point (see range lock), it will either stop or reset to zero and keep counting depending on this option.

0 - With value set to zero, display will stop.

1 - With value set to 1, display will keep counting from zero.

Area 3 - On Zero

When the display is being used as a countdown timer and it reaches zero, it decides what to do based on the value in this area.

0 - Stop

1 - Reload with "Reload" time and stop

2 - Reload with "Reload" time and continue

3 - Begin Counting Up

Area E - Military Time

When set as a clock, the display will look at this area to determine if military time is active.

0 - 12 Hour Clock mode

1 - 24 Hour Military Time Mode

Area D - Start/Stop Button Logic

This area only affects the external buttons and count up/down timers. The display looks at the value in this area to determine what to do the "third" time the button connected to "Input 1" is pressed. The first time the button is pressed, the display always starts. The second time the button is pressed, the display always stops. The third time the button is pressed, the display will either start again, go to zero, or reload and start again, or go to zero or reload and stop. If the display is counting up, it will go to zero.

Understanding Programmable Options

If it is counting down it will reload the reload time.

- 0 - Zero or Reload and Start
- 1 - Zero or Reload and Stop
- 2 - Start/Stop/Start (Factory Default)

Area V - Set Reload Time

This memory area is used to store the 6-digit reload time for timers. When a timer reaches zero while counting down, it looks in this area for the time to reload.

Area Y - Set Chime Time

This area stores the 6-digit time value at which the display will chime. This can be used with count up/down timers to set a chime at a given point in the count or with a clock to serve as an alarm.

Area 6 - Display Size

The display looks at this area to see how many digits it has. It is set at the factory to match the number of digits of your display; i.e. a 3-digit display would have a "3" in this option. The only reason you would change this value would be to fool the display into thinking it had a different number of digits than it really had. You may want to call technical support if your needs are this complex.

Area 7 - Least Significant Digit Lock

This area sets the smallest time increment that will be shown on a display; i.e. if you want your 4-digit display to only show hours and minutes and never seconds, you would set this value to "2."

- 0 - not used
- 1 - 4 = Seconds, Minutes, Hours, Days

Area 8 - Most Significant Digit Lock

This area sets the largest increment of time the display will show: For example, if you want your display to count more than 24 hours but did not want it to roll over to days, you would set this value to "3" for hours.

- 0 - Not Used
- 1 - 4 = Seconds, Minutes, Hours, Days

Area F - Flash Colons

This area allows you to change which colons can be turned on.

- 0 - No Colons Flash
- 1 - Left Colons Flash (6-Digit Display Only)
- 2 - Right Colons Flash
- 3 - Both Colons Flash

Area G - Colon Flash Rate

Use this area to control how fast your colons flash.

- 0 - Colons stay on all of the time
- 1 - Colons flash once a second
- 2 - Colons flash twice a second
- 3 - Colons flash four times a second

Take-A-Number Options

Area B - Leading Zero Suppression

The value in this area determines whether or not your display will show leading zeros; i.e., the difference between seeing "1" on your display and seeing "000001."

- 0 - Shows leading zeros
- 1 - Does not show leading zeros

Area H - Display Address "Tens" Digit

This is used in the Multi-Window Service System configuration to set the address of Window Slaves; stores a value from 0-9. See the Multi-Window Service System section of the manual for further details.

Area I - Display Address "Ones" Digit

This is used in the Multi-Window Service System configuration to set the address of Window Slaves; stores a value from 0-9. See the Multi-Window Service System for further details.

Chime Options

The display comes standard with an internal chime. In addition, an external "chime driver" circuit can be purchased at the time of order. Both the internal chime and the external "chime driver" activate at the same time. The "chime driver" circuit can be connected to an external doorbell or other 24VAC device. For details on the "Chime Driver" circuit, see the "Chime Driver" specifications in this manual. Unless otherwise specified, both the options below effect both the internal chime and the chime driver circuit.

Area 4 - Chime on Zero

When the display is used as a countdown clock, it will activate the chime when it reaches zero based on this value.

- 0 - Do not activate chime when counting down to zero.
- 1 - Activate the chime when counting down to zero.

Area 5 - Chime Duration Chime Driver Circuit Only

This area is valid only if you have purchased the optional chime driver circuit. The display looks at this area of memory to determine how long to allow the current to flow through the external chime circuit. Values can be set from 0 -9 with each increment adding 0.1 seconds to the value. See the "Programming Area Table" for a complete listing.

Area J - Internal Chime Options

This area controls the volume and sound of the internal chime. The single chime is a "Ding-Dong" sound where a double chime is a "Ding-Dong, Ding-Dong" sound.

- 0 - Internal Chime Off
- 1 - Low Volume Single Chime
- 2 - High Volume Single Chime
- 3 - Low Volume Double Chime
- 4 - High Volume Double Chime

Setting the Programmable Options

Intro to Setting Options

This section describes how to set the options on the 5400 display. To understand the function of each option, see "Understanding Programmable Options."

This page references the table on the next page extensively. As you look at the table on the next page, you should see four distinct areas: "Remote Control Quick Set," "Push Button Quick Set," "Standard Options" and "Push Button Time Set."

The "Quick Set Areas" are used to quickly set all of the other "standard option" areas in memory to typical application settings. The "Standard Options" area stores the actual settings for the display. The "Push Button Time Set" area is used to set the reload and chime times if you do not have a remote control.

There are two ways to set the options on the display. Please skip to the section below discussing your method.

Setting the Options with a Remote Control

Pressing the "MENU" button on the remote will access the programming mode. The "UP/DOWN" buttons will move you through the areas. Where applicable, the numbers on the remote will change the values. The "ENTER" button will save the changes and exit the programming mode.

When you press the "MENU" button on the remote control, you will see a "-1." This corresponds to the "-1" at the top of the chart on the next page. Pressing the "UP" button on the remote will move you through the chart to "-6," and then back to "-1." Option "-1" through "-3" are used to quickly change the mode of the display. For instance to change to a clock, simply press the "ENTER" button with the display showing "-3."

To set the reload time or the chime time, press the "ENTER" button with either "-4" or "-5" showing on the display. Then using the numbers on the remote enter a 6-digit time then press "ENTER" to save.

To set the standard options of the display press the "UP/DOWN" until you see a "-6" on the display, then press the "ENTER" button. You will then see "00" on the display corresponding to the "00" on the "Push Button Quick Set" on the chart on the next page. Press the "UP" button to move through the areas in the standard options. When you find the option you want to change, type the value using the numbers on the remote; then press the "ENTER" button to accept the changes and exit programming, or press the "EXIT" changes to quit without saving.

You will not use the "Push Button Time Set" with the remote control.

Setting the Options Using the Programming Buttons

(on the back of the display)

To get into programming mode, press the "mode" button. The display will show "00" corresponding to the "00" in the "Push Button Quick Set" on the table on the next page. Pressing the "advance" button will increment the value of a given area. Pressing the "mode" button will move you through the areas.

When in the "quick set" area, pressing "select" will set all of the options to the given application type and save and exit the programming mode.

To change the value of an option in the "standard options area," press the "mode" button until you reach the desired area. Then press the "advance" button to change the value of the area. Press "mode" again to move to another area or press and hold "mode" to save changes and exit. To exit without saving changes, simply wait 30 seconds without pushing any buttons.

To set the chime time or reload time using the push buttons, press

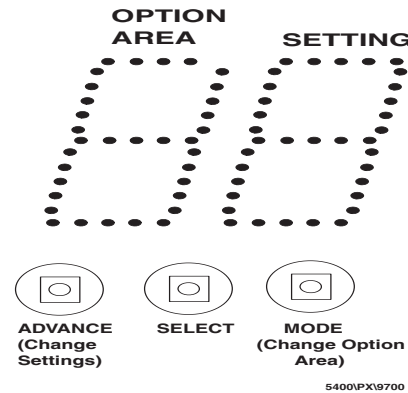

the "select" button with the appropriate area showing. The display will show "DD." Use the following example to set the time:

To set the current time to:

Days	Hours	Minutes	Seconds
DD	HH	MM	CC
01	10	07	18

With the display showing "DD" you are now in the time setting mode. To set the time:

Action	Times	Display*
		<u>DD</u>
Select	1	<u>DD</u>
Advance 1	<u>0</u> 1	
Select	1	<u>HH</u>
Advance 1	<u>1</u> 0	
Select	1	<u>HH</u>
Select	1	<u>MM</u>
Select	1	<u>MM</u>

Options Table

(options in **bold** are the default settings)

Quick Set (Remote Control Only)

- 1 Take-A-Number
- 2 Count Up/Down Timer
- 3 Clock
- 4 Set Reload Time
- 5 Set Chime Time
- 6 Enter Option Area (Below)
- Area Setting
- 0 Quick Setup
 - 00 =Time-of-Day Clock
 - 01 =Count Up
 - 02 =Countdown
 - 03 =**Standard Take-A-Number**
- 1 Display Mode
 - 10 =Time-of-Day Clock
 - 11 =Count Up
 - 12 =Countdown
 - 13 =Slave Listen
 - 14 =**Lobby Master**
 - 15 =Lobby Slave
 - 16 =MWSS Clerk Slave Auto Address
 - 17 =MWSS Clerk Slave Manual Address
- 2 On Roll Over
 - 20 =**On Roll Over Stop**
 - 21 =Continue
- 3 On Zero
 - 30 =On Zero Stop
 - 31 =**On Zero Reload and Stop**
 - 32 =On Zero Reload and Continue
 - 33 =On Zero Count Up
- 4 Chime on Zero
 - 40 =**Chime on Zero OFF**
 - 41 =Chime on Zero ON
- 5 Chime Duration for External Driver
 - 50 =Chime Off
 - 51 =Chime Time = .1 Sec
 - 52 =Chime Time = .2 Sec
 - 53 =Chime Time = .3 Sec
 - 54 =**Chime Time = .4 Sec**
 - 55 =Chime Time = .5 Sec
 - 56 =Chime Time = .6 Sec
 - 57 =Chime Time = .7 Sec
 - 58 =Chime Time = .8 Sec
 - 59 =Chime Time = .9 Sec
- 6 Display Size (Factory Set)
 - 61 =Not Applicable
 - 62 =2-Digit Display
 - 63 =3-Digit Display
 - 64 =4-Digit Display
 - 65 =Not Applicable
 - 66 =6-Digit Display
- 7 Least Significant Digit Range Lock
 - 70 =
 - 71 =**Seconds**
 - 72 =Minutes
 - 73 =Hours
 - 74 =Days
- 8 Most Significant Digit Range Lock

- =
 - 80 =Seconds
 - 81 =Minutes
 - 82 =Hours
 - 83 =**Days**
 - 9 Push Button Input
 - =**Push Button, no voltage applied**
 - 90 =Voltage applied = 5 Volts
 - A Input State
 - =**Normally Open Button or No voltage**
 - A0
 - A1 =Normally Closed Button or +5 Volts
 - B Suppress Leading Zeros (Take-A-Number only)
 - b0 =Shows Leading Zeros
 - b1 =**Suppresses Leading Zeros**
 - C Button Logic
 - C0 =**Momentary Button Press**
 - C1 =Change of State (switch)
 - C2 =Momentary, No quickset
 - D Third Button Press
 - d0 =Zero or Reload and Start
 - d1 =Zero or Reload and Stop
 - d2 =**Toggle Start/Stop**
 - E 12/24 Hour Mode for Clock
 - E0 =**12-hour Mode**
 - E1 =24-hour Mode
 - F Colons to Flash
 - F0 =No Colons Flash
 - F1 =Left Colons Flash (6-Digit Only)
 - F2 =Right Colons Flash (3-, 4-, & 6-Digit Only)
 - F3 =**Both Colons Flash (6-Digit Only)**
 - G Colon Flash Rate
 - g0 =Colon Stay ON
 - g1 =Colon Flash Once a Second
 - g2 =**Colon Flash Twice a Second**
 - g3 =Colon Flash Four Times a Second
 - H Set Display Address Tens
 - h- =Display Address Ten = 0
any number 0 to 9 valid
 - I Set Display Address Ones
 - i- =Display Address Ones = 1
any number 0 to 9 valid
 - J Set Internal Chime Volume
 - J0 =**Internal Chime OFF**
 - J1 =Low Volume Single Chime
 - J2 =High Volume Single Chime
 - J3 =Low Volume Double Chime
 - J4 =High Volume Double Chime
 - L IR Lockout
 - L0 =Ignore remote control
 - L1 =**Respond to remote**
- It is highly recommended that you use the remote control to set the following functions, otherwise see manual for using "mode/select/advance" buttons on the back panel.
- upper case U =Set Time-of-Day or Start Time
 - lower case u =Set Reload Time
 - Y =Set Chime Time

Multi-Window Service System (MWSS)

System Overview

A Multi-Window Service System is an advanced Take-A-Number system. In a typical MWSS application, there are several clerks at a service counter. All of the clerks are serving a "pool" of customers with sequentially numbered tickets. The system can be best understood by studying the concept drawing on the next page.

There are three types of displays shown in the concept drawing. The 5400 Series displays can be set to any of these types using the programmable options.

Lobby Master

The "Lobby Master" display shows the highest number being served. There can only be one "Lobby Master" per system.

Lobby Slave

The "Lobby Slave" displays show the same number as the "Lobby Master." You can have as many "Lobby Slaves" as you need.

Window Slave

"Window Slave" displays show the number currently being serviced by a clerk. You can have as many "Window Slave" displays as you need. Push buttons are attached to each window slave display.

System Operation

Push buttons are generally connected to the window slave displays. When the clerk pushes the button connected to the window slave, the lobby master and lobby slave displays will increment by one. The window slave, whose button was pushed, will show the same number as the lobby master. Other window slaves will not change. In this way customers in the waiting area will be able to see that their number is being called and see which clerk to go to for service.

Setting Up the System

To set up a Take-A-Number System, first wire the system as shown in the "Take-A-Number Wiring Diagram" on page 18. Next, program the display to the appropriate value in Area 1. Setting Area 1 to a 4 will cause the display to be a lobby master; setting Area 1 to a 5 will cause the display to be a lobby slave, and setting Area 1 to a 6 will cause the display to be a window slave. See the "Setting Programmable Options" section for details on how to change these values.

All displays may be hung on the wall like a picture. See the "Mounting Template" section for easy wire cutouts when running wire through the wall.

Special Case MWSS

In some cases, it may be necessary to have two window slave displays showing the same number. For instance, each service had one display facing the customer and another display facing the clerk so that the clerk could see the number they were about to serve. In this case all of the window slave displays will have to be set to "MWSS Clerk Slave Manual Address." This is done by setting Area 1 to a value of 7. In addition, each window slave display will have to be assigned an "address." This is done by setting the values of areas "H" and "I." Window slave displays with the same address will show the same number. For details on setting the values of these areas, see the section "Setting the Programmable Options."

Multi-Window Service System Concept

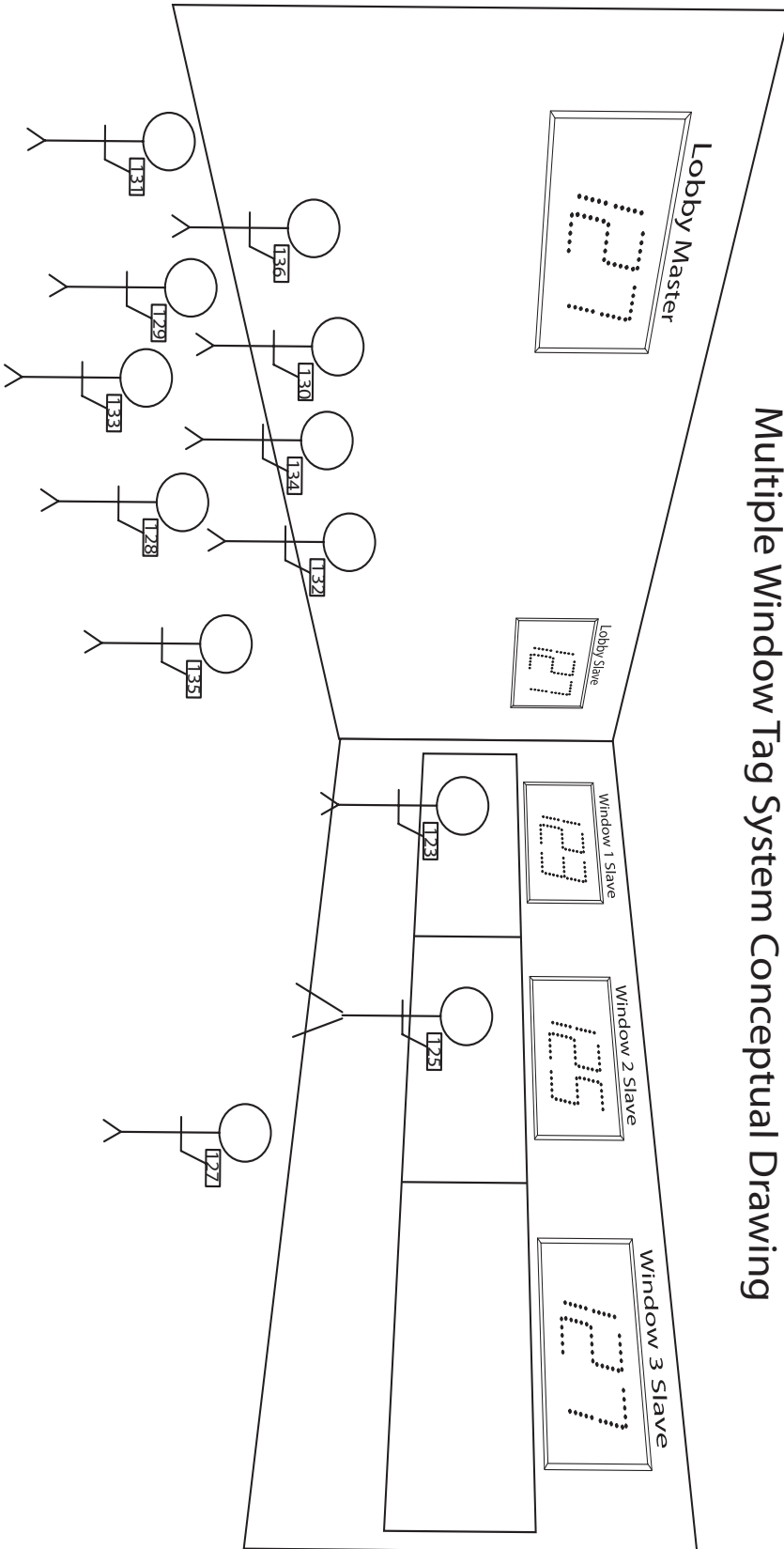

Multiple Window Tag System Conceptual Drawing

Multi-Window Service System

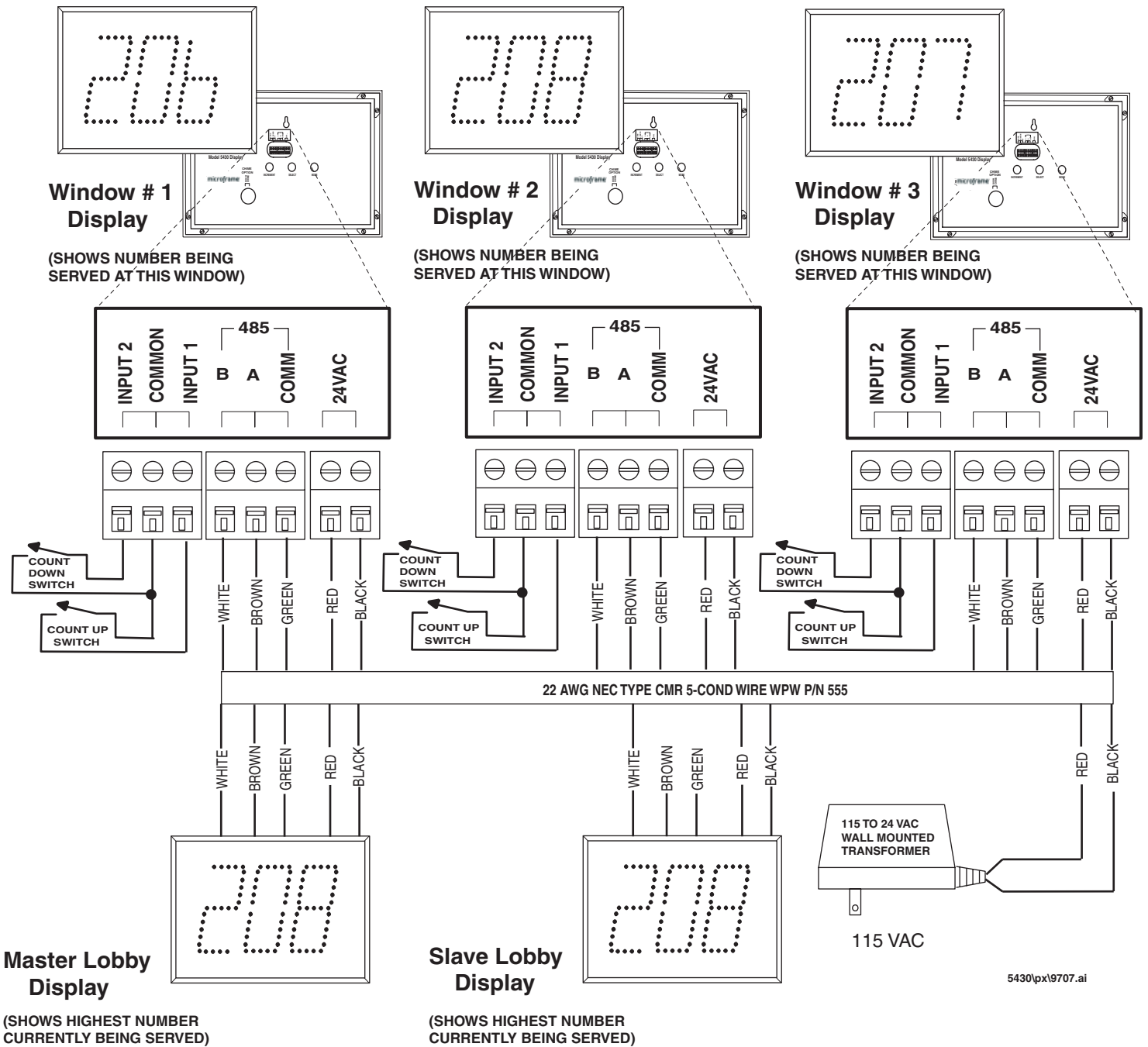



Model 5400 Specifications Stand-Alone Displays

Features

The 5400 Series display is a 2-, 3-, 4-, or 6-digit intelligent LED display with infrared capabilities. This display has two inputs for buttons or logic controls and a communications link for communicating with other displays. Displays are powered by a 24-Volt AC adapter (included). These displays can be configured to count events occurring at their inputs, or as Timers using the inputs as start/stop controls. Common uses include:

- Take-A-Number Systems for customer service
- Event Timers
- Time-of-Day Clocks
- Production Productivity Displays (Time and/or Count)

Displays include a built-in audio chime and optional remote control.



5420



5460



5430



5440

Operation

First, connect the remote switches or controller to the display inputs "1" and "2" (if used). Next, connect the AC power adapter (included) to the display and plug into an AC outlet. The programmable options may now be set using the mode, select, and advance buttons (see programming instructions).

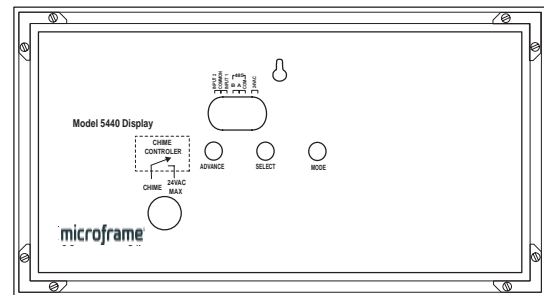
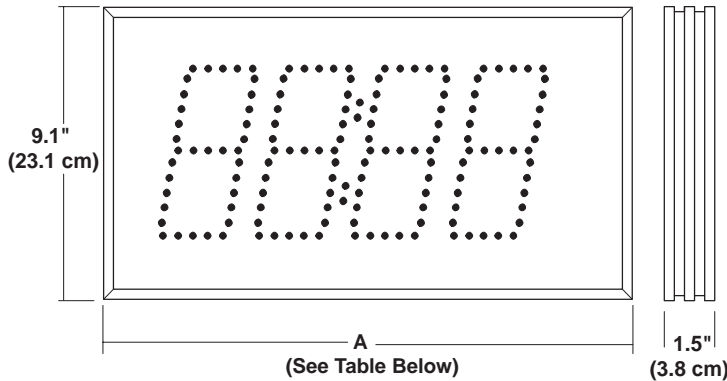

54X0\ax\9702.ai

Model 54X0 Specifications

Voltage Input Requirements	24 volts AC or DC			
Character Height	5.5 Inches			
Character Viewing Distance	125 Feet			
Temp.....	-20°C to 70°C or -4°F to 158°F			
Case	Aluminum Extrusion			
Color.....	Black Frame w/ Dark Red Plexiglas Faceplate			
Environment	Indoor Use (See Factory for Outdoor Cases)			
Display Size.....	2-Digit	3-Digit	4-Digit	6-Digit
Power Requirements	2.9 Watts	3.5 Watts	4.6 Watts	6.8 Watts
Weight	2.5 lbs	3 lbs	3.5 lbs	5.25 lbs
Width "A" Dimension Inches.....	9.8"	13.2"	16.8"	24"
Width "A" Dimension Centimeters....	24.9 cm	33.5 cm	42.7 cm	61.4 cm

Support and Sales

800-635-3811

Microframe® Corporation
www.microframecorp.com

P.O. Box 1700
Broken Arrow, OK 74013

General Troubleshooting Chart

SYMPTOM	POSSIBLE CAUSE	CURE
Display will not light up.	Display is not connected to power or power adapter is bad.	Check AC wall connection or change to another wall outlet.
Display lights up but will not respond to buttons.	Poor or no signal connection to buttons.	Check signal cable connections to buttons and check for proper wiring on back panel. Try with a short cable to prove whether the problem is in the units or in the cable.
One or more segments do not light up.	One or more LEDs burned out. This typically happens only when lightning strikes.	Call Microframe to receive an RMA and then return to factory for repair.
Different displays are showing different numbers or times.	Poor signal connection to master display or displays are in different modes.	Check signal cables and routing. Make sure 'A' and 'B' wires are not reversed. Check Programmable Options to make sure correct modes are selected.
Display in MWSS mode decrements three or fewer times.	MWSS slaves are only allowed to decrement if they just incremented (to correct mistakes).	Use the master decrement to roll back the entire system.

Take-A-Number Troubleshooting Chart

One of the digits starts flashing when the up button is pressed.	The display has been put into quickset mode by holding the up button.	Press the button for a shorter time. To increment just the ones digit, hold the button until the left-most digit stops flashing.
On a multi-unit installation, pushing the up button causes multiple increments, possibly after a delay.	The same button has been connected to more than one display.	Connect the button to just one display.
After adding another display, one or more displays are incrementing on their own.	One of the displays is in clock mode.	Reset mode on each display to Take-A-Number mode, using quickset 03.

Timer/Clock Troubleshooting Chart

Colons do not flash or they stay on.	Programming set to disable colons or flash rate. Display is not getting enough power.	Check the programming and change as necessary.
--------------------------------------	---	--

Remote Control Troubleshooting

Remote control buttons stopped responding.	Batteries are dead.	Replace batteries.
--	---------------------	--------------------

5400 Remote Display Mounting Template

TOP OF DISPLAY



5420 REMOTE DISPLAY DRILL TEMPLATE

Drill 1" Diameter Hole

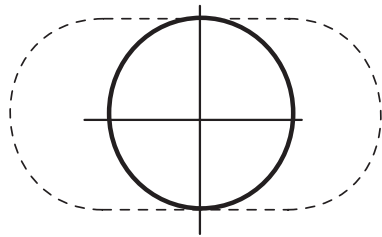

TOP OF DISPLAY

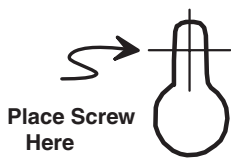

5440



5430 / 5460

NOT TO SCALE
LOCATE 9 3/4" APART

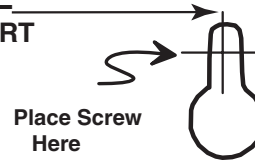

2nd MOUNTING HOLE FOR
5460 REMOTE DISPLAY

Drill 1" Diameter Hole

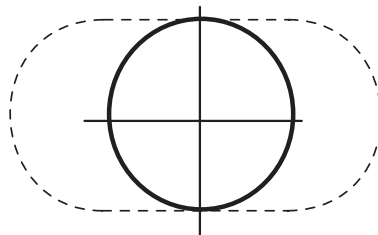

5430,40, 60 REMOTE DISPLAY DRILL TEMPLATE

microframe[®]

Microframe Corporation
604 S. 12th Street
Broken Arrow, OK 74012

Tel: (918) 258-4839
Toll Free: 1-800-635-3811
Website: www.microframecorp.com
E-mail: support@microframecorp.com