

microframe® MODEL 920, 930, and 940 SPECIFICATIONS Remote Displays

Features

The Model 920, 930, and 940 Displays are designed to work with the Timer Keypad. Each Display has 5.5 inch tall digits viewable up to 125 feet and is encased in an aluminum extruded cabinet.

Operation

The Remote Display is designed to operate with the Model 904 Keypad or Model 6200 Timer Keypad. The Remote Display receives power and signal from a single cable connected to the Keypad and is turned on or off with the Keypad power switch.



Microframe® Model 940 Display

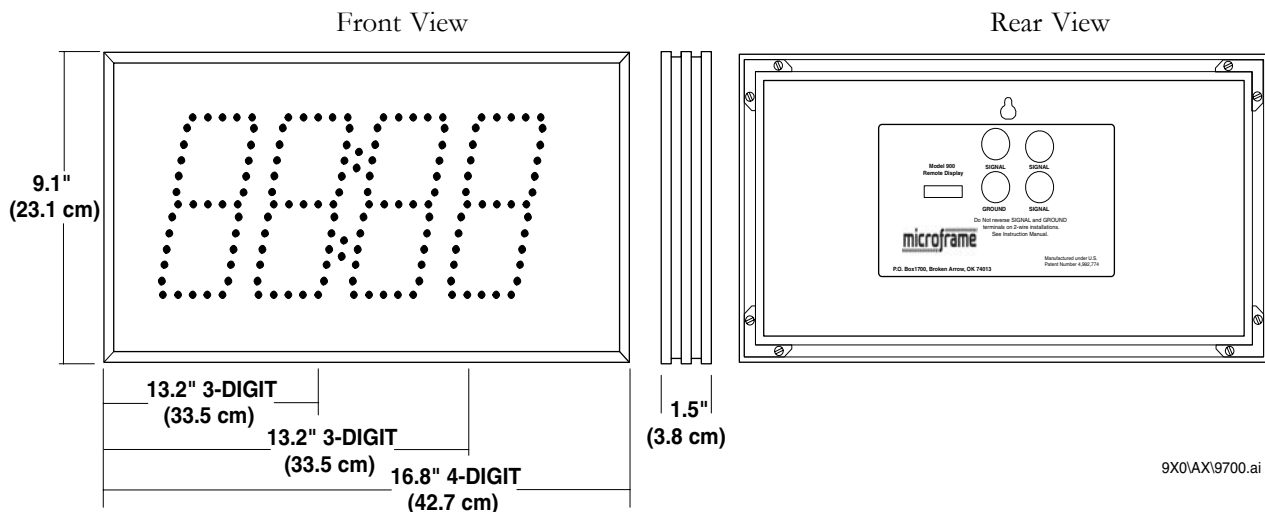

Model 920, 930 and 940 Specifications

Remote Display	Wall mount 5.5" LED Display
Maximum Distance from Keypad	2,000 Feet = 1 Display 300 Feet = Full Load of Displays Using 16 AWG Paired Wire
Power Input Requirements	Power Supplied by Keypad
Maximum Number of Displays without Booster Amp	Up to twelve 2-Digit; nine 3-Digit and seven 4-Digit Displays
Character Height	5.5 inch (14 cm)
Character Viewing Distance	150 feet (45 meters)
Weight	2-Digit, 2.5 Lbs (1.1 kg); 3-Digit, 3 Lbs (1.4 kg); 4-Digit, 3.5 Lbs (1.6 kg)

Support and Sales
800-635-3811

Microframe® Corporation
www.microframecorp.com

P.O. Box 1700
Broken Arrow, OK 74013