

Microframe Corporation

A0262:
RS232 Remote Display



(shown in optional casing)

Operating Manual

A0262-7010





A0262

INSTALLATION & SPECIFICATION GUIDE

ITEM NO: A0262
REVISION DATE: 07/06

Microframe Corporation
604 S. 12th Street
Broken Arrow, OK 74012

Tel: (918) 258-4839
Toll Free: 1-800-635-3811
Website: www.microframecorp.com
E-mail: support@microframecorp.com

Limited Warranty Agreement

Your Microframe System is warranted against failure due to defects in workmanship or material for a period of one (1) year from the date of purchase. Microframe Corporation will repair or replace any defective unit. Obvious abuse or mishandling of the unit is NOT covered by this warranty.

Merchandise Return

If your Unit does not work satisfactorily, please give us a call. We may be able to clear up the problem by phone. If it becomes necessary to return your Unit to the factory, please observe the following.

1. Place Unit in a sturdy box with sufficient packing material.
2. If requested, include the AC power adapter. It is not necessary to return the cable and connectors unless they are the problem.
3. Return the system insured and prepaid since we are not responsible for shipping damages and losses on returned Units.

Warranty Service

For warranty service, please contact Microframe at 1-800-635-3811. A technician will gladly assist you.

Assistance

For any product assistance or maintenance help, contact Microframe by calling 1-800-635-3811 or emailing us at support@microframecorp.com.

Safety

Do not install substitute parts or perform any modification to the product without first contacting Microframe.

Warning

All AC power adapters, line cords, and electrical equipment should be kept out of the reach of children and away from water. (If you are installing cable in an air plenum area, such as a drop ceiling used for air return, you must use plenum-rated cable. The cable supplied from Microframe is rated CL2 and is approved for installation everywhere indoors except plenum areas.)

Life Support Policy

Microframe's products are not authorized for use as components in life support devices or systems without the express written approval of the president of Microframe Corporation. As used herein:

1. Life support devices or systems are defined as systems which support or sustain life, and whose failure to perform when properly used in accordance with instructions for use provided in the labeling, can be reasonably expected to result in a significant injury to the user or any one depending on the system.

2. A critical component is any component of a life support device or system whose failure to perform can be reasonably expected to cause the failure of the life support device or system, or to affect its safety or effectiveness.

Disclaimer

We are constantly striving to improve our products. Due to this, specifications are subject to change without notice.

TABLE OF CONTENTS

MODEL A0262 SPECIFICATIONS	6
1 PROTOCOL	7
1.1 DISPLAYING A NUMBER	7
1.2 OPERATING THE DECIMAL	7
1.3 OPERATING THE COLON	7
1.4 SELF-TEST	7
1.5 LEADING ZERO SUPPRESSION	7
1.6 SELECTING BAUD RATE	7
1.7 UNIT ADDRESSING	7
1.8 MIRROR MODE	7
1.9 OPTION SWITCH SUMMARY	7
CONNECTION and OPTION SELECTION.....	9
2 FLASH PROGRAMMING	10



MODEL A0262 SPECIFICATIONS

Remote Display

Features

The Model A0262 Remote Display is designed to operate with any standard RS232 input to provide Remote Display capabilities for a computer, PLC or scale display. The Model A0262 Display has 1.5-inch tall digits and is encased in an aluminum extruded cabinet.

Operation

The computer passes ASCII characters and a carriage return (ASCII 13D), and then the characters will be displayed on the Model A0262. To display a blank screen, pass a carriage return (ASCII 13D). Insert the decimal point in the number string and it will light. Pass a colon (:) and the right colon on the Display will light. Pass a percent sign (%) and the left colon will light. Leading zeros will be blanked if the user selectable option switch is enabled.



Microframe® Model A0262 Display

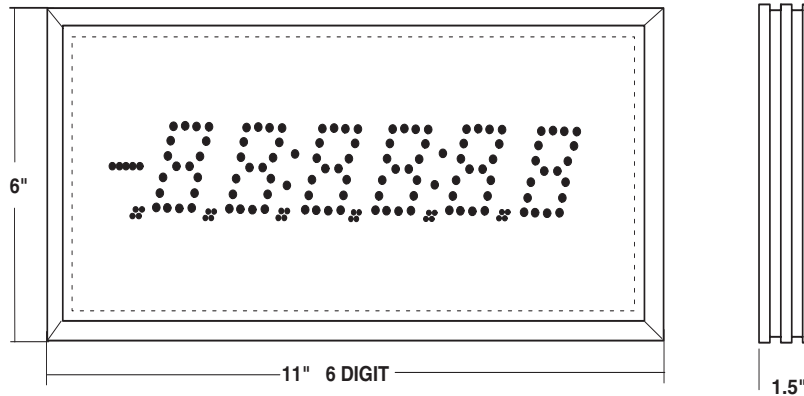

260\AXI9700E.ai

Model 262 Specifications

Protocol	RS232
Power Input Requirements	16-24 VAC
Baud Rate.....	1200 to 9600 Baud Switch Selectable
Maximum Number of Addresses	7 Different Display Addresses
Digit Height	1.5 Inch
Operating Temperature.....	-20° C to 60° C or -4° F to 140° F

Support and Sales
800-635-3811

Microframe® Corporation
www.microframecorp.com

P.O. Box 1700
 Broken Arrow, OK 74013

1 PROTOCOL

1.1 DISPLAYING A NUMBER

The Display will show as many characters as it has digits preceding a carriage return.

(CR)=Carriage Return or ASCII 13d or OD hex

1.2 OPERATING THE DECIMAL

The decimal point can be operated by simply placing the decimal in the number string where you want it to display. (SEE CHART 1 BELOW)

1.3 OPERATING THE COLON

You may turn the right colon "ON" by passing a colon (:). You may turn the left colon "ON" by passing a percent sign (%.)

1.4 SELF-TEST

Self-test can be selected by using OPTION SWITCH 1 & 2. OPTION SWITCH 1 "ON" shows all "8888." Switch both 1 & 2 "ON" and all numbers will count from "0000" through "9999" continuously. This allows for a visual check of all the LEDs.

1.5 LEADING ZERO SUPPRESSION

The Display can suppress leading zeros if OPTION SWITCH 3 is "ON." Set OPTION SWITCH 3 "OFF" to defeat leading zero suppression.

Entered	Shown
0001(CR)	0001 Switch 3 "OFF"
0006(CR)	6 Switch 3 "ON"

1.6 SELECTING BAUD RATE

The Display communicates at the selected baud rate with 8 bits, no parity. You may select the communications baud rate with OPTION SWITCH 4 and 5 as follows:

Switch	Baud Rate	Switch	Baud Rate
<u>5</u> <u>4</u>		<u>5</u> <u>4</u>	
0 0	=1200 Baud	1 0	= 4800 Baud
0 1	=2400 Baud	1 1	= 9600 Baud

1.7 UNIT ADDRESSING

The Microframe Displays can be addressed in the following manner. Address 0 responds to all data.

OPTION SWITCH			
<u>8</u> <u>7</u> <u>6</u>			
0 0 0			Display Address is 0

(cont.)

<u>8</u> <u>7</u> <u>6</u>			
0 0 1			Display Address is 1
0 1 0			Display Address is 2
0 1 1			Display Address is 3
1 0 0			Display Address is 4
1 0 1			Display Address is 5
1 1 0			Display Address is 6
1 1 1			Display Address is 7

To enable Display address number 1, pass the following enable code:

ASCII	SO	0	1	ETX
HEX	0E	30	31	03

To disable Display address number 1, send the following code:

ASCII	SI	0	1	ETX
HEX	0F	30	31	03

- 0E Hex = Enable command
- 0F Hex = Disable command
- 03 Hex = Command string termination
- Address 0 = Responds to all data

To enable Display 2 and send "1234," then disable it, send the following.

0E	30	32	03
31	32	33	34
0F	30	32	03

1.8 MIRROR MODE

This mode allows numeric characters to be viewed correctly in a mirror.

To enable mirror mode for Display 1, send the following code:

ASCII	ESC	0	1	ETX
HEX	1B	30	31	03

To disable mirror mode on Display 1, send:

ASCII	SUB	0	1	ETX
HEX	1A	30	31	03

If the Display is at address zero send

HEX	1B	30	30	03
HEX	1A	30	30	03

1.9 OPTION SWITCH SUMMARY

Switch	Function
1 on =	Self-Test All "8888"
1 & 2 on =	Self-Test All Count "0000" to "9999"
3 on =	Disable Leading Zero Suppres-sion
4	Baud Rate Selection
5	Baud Rate Selection
6	Set Address
7	Set Address
8	Set Address

Supported Character Set

Mirrored Characters

Hex	ASCII
Displayed	A
41,61.....	A,a.....
42,62.....	B,b.....
43,63.....	C,c.....
44,64.....	D,d.....
45,65.....	E,e.....
46,66.....	F,f.....
47,67.....	G,g.....
48,68.....	H,h.....
49,69.....	I,i.....
4A,6A.....	J,j.....
4C,6C.....	L,l.....
4E,6E.....	N,n.....
4F,6F.....	O,o.....
50,60.....	P,p.....
52,62.....	R,r.....
53,63.....	S,s.....
54,64.....	T,t.....
55,65.....	U,u.....
56,66.....	V,v.....
59,69.....	Y,y.....
20.....	' ' <Blank>
2A.....	'*' <Asterisk>
2D.....	'-' <Dash>
40.....	'@' <AT>
5F.....	'_' <Underscore>
7E.....	'~' <Tilde>

	Normal	Mirrored
0.....	0.....	0.....
1.....	1.....	1.....
2.....	2.....	2.....
3.....	3.....	3.....
4.....	4.....	4.....
5.....	5.....	5.....
6.....	6.....	6.....
7.....	7.....	7.....
8.....	8.....	8.....
9.....	9.....	9.....

CONNECTION and OPTION SELECTION

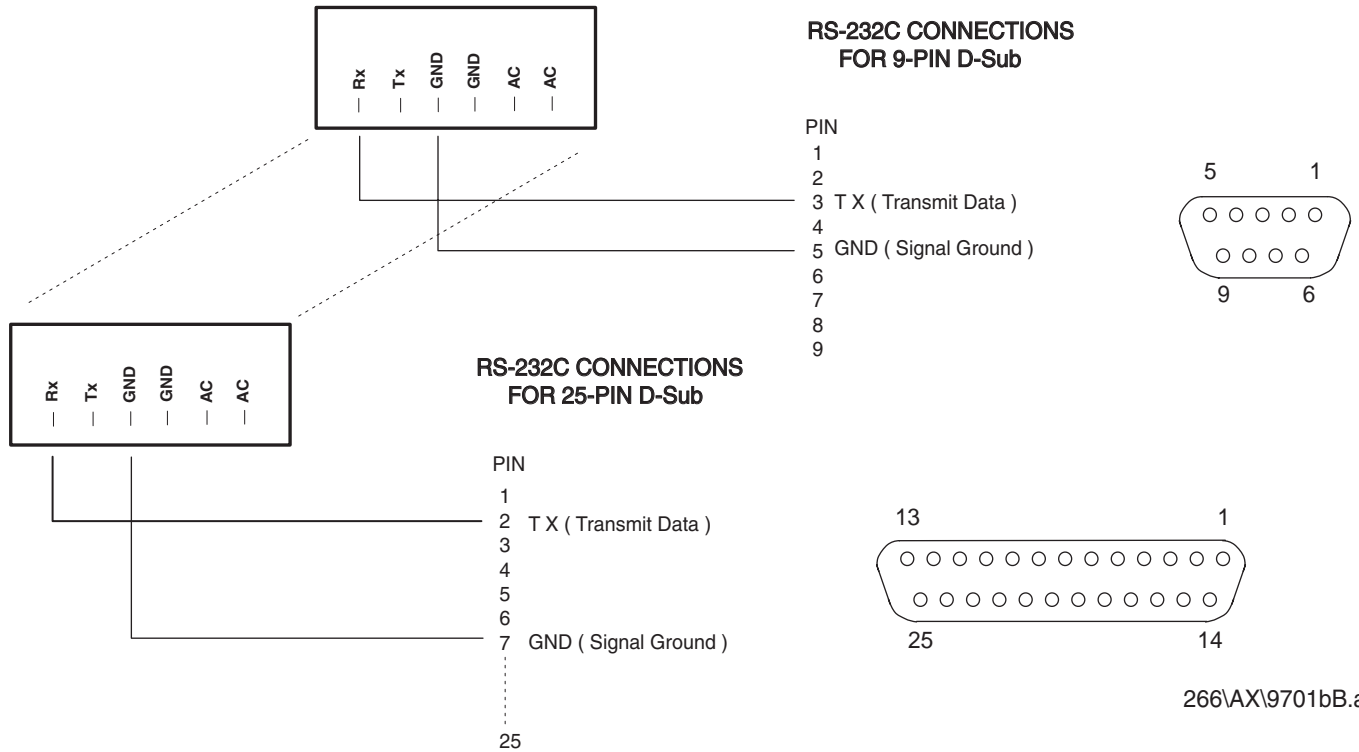

266\AX\9701bB.ai

Be sure to set your computer ComPort to [Flow Control=None]. This will allow you to communicate with the display without a null modem. Otherwise, your computer will be looking for a "Clear to Send" from the display which is not connected.

2 FLASH PROGRAMMING

The Model 262 Displays are now being shipped with the ability to be reprogrammed in the field. This may be useful if a customer's requirements change after they have purchased a system. This will also allow software upgrades and system enhancements to be added without sending the Display back to the factory.

There are two major steps to upgrading the Display software:

- 1.) Place the Display in programming mode;
- 2.) Using a PC and the supplied Microframe flash utility, send the new file to the Display.

Below are the exact order of events for upgrading the software. This assumes you already have the transmit and receive from your computer connected to the receive and transmit of the Display.

1. If you have not already done so, install the Microframe Flash utility program by running: setup.exe
2. Open Flash utility program by going to: start /programs/flashutil/flashutil
3. Click on "Load Rom File" and select the ROM file supplied by Microframe that you would like to place in the processor.
4. Estimate the current Display temperature and select the appropriate range.
5. Turn the Display off.
6. Turn on only Dip Switch 2.
7. Turn the Display on.
8. Within 5 seconds turn Dip Switch 2 off.
9. Within 15 seconds, click on flash button from flash utility.

NOTES:

If Dip Switch 2 is not turned off within 5 seconds of power on, the Display will return to normal operation.

If no data is received from the Microframe Flash Utility within 15 seconds of Dip Switch 2 being turned off, the Display will return to normal operation.